

SILICON VHF/UHF TUNING VARACTORS

DESCRIPTION

DC4200 series varactors are abrupt junction devices of planar-epitaxial construction. They are intended for electronic tuning and other frequency control applications in the VHF/UHF region. Device performance has been optimised by careful attention to processing techniques. The use of oxide/nitride passivation produces varactors with good stability and low leakage. Low substrate resistance and optimised metal contact schemes help to minimise series resistance, resulting in high values of Q. Capacitance values ($C_T - 4V$) from 2.2 to 350 pF are available in a range of appropriate packages.

HIGH RELIABILITY

DC4200 series varactors are designed for high quality and high reliability applications. MEDL Microwave has a proven record of supplying high reliability devices for military programmes. Every device shipped from the factory must meet the strict standards of U.K. Ministry of Defence approval to NATO AQAP-1 (Edit. 3).

In addition, DB4200 series varactors are available to CECC 50 077. To qualify devices undergo severe mechanical and environmental testing* similar to that required to MIL 202. This is backed up by long term reliability testing.

MTBF's (Mean Time Before Failure) of $>10^7$ hours are typical. Special screening can be performed on most device types and can be tailored to meet specific requirements. Contact our local representatives for further information.

*BS2011 and IEC 68 series test programme

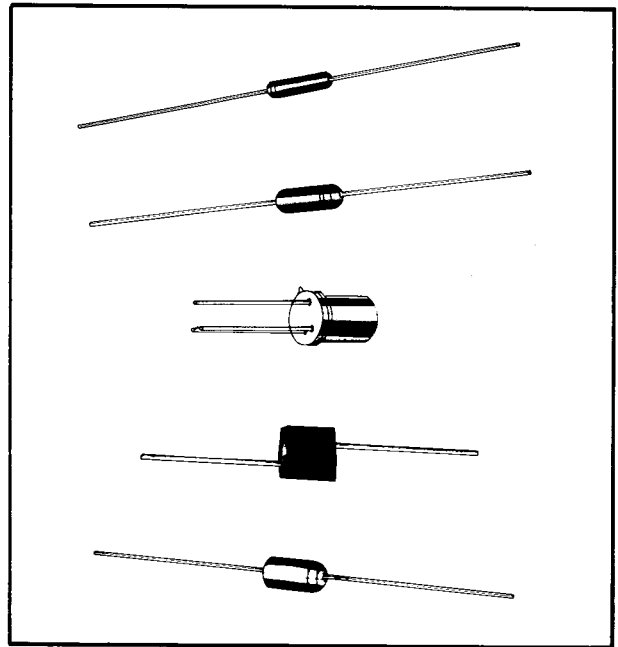

- High Q
- Large tuning range
- Designed for high reliability
- Wide range of capacitance values
- High capacitance tolerance
- Many special selections available

MEDL
MICROWAVE

Marconi Electronic Devices Limited,
Microwave Division,
Doddington Road, Lincoln LN6 3LF, England.
Tel: 0522 688121 Telex: 56380 Fax: 0522 690916 (to 3/4/88 only)
Tel: 0522 500500 Telex: 56380 Fax: 0522 500550 (from 4/4/88 onwards)

M74
Issue 1
November '87

**SILICON VHF/UHF
TUNING VARACTORS**

LIMITING CONDITIONS OF USE

Maximum Reverse Voltage (V _R)	60V
Storage Temperature Range	-55°C to + 150°C
Operating Temperature Range	-55°C to + 100°C

ELECTRICAL CHARACTERISTICS at T_{amb} = 25°C

The table of electrical characteristics gives an appreciation of the range of varactors available. However, the range can be extended to meet individual customer requirements. Special features available include:

- **Tighter tolerance and matched sets**
- **100% burn-in**
- **Choice of minimum breakdown voltage**
- **Special reliability testing**
- **Higher Q**
- **Wider bandwidth tuning**

Type No.	Outline No.	Total Capacitance C _T ±10% (pF)	Capacitance ratio (min.)	Breakdown Voltage V _B (V)	Quality Factor Q	Test Frequency f (MHz)	Reverse Voltage V _R (V)
DC4255B	35	2.2	2.5	60	550	50	-4.0
DC4256B	35	3.3	2.7	60	450	50	-4.0
DC4257B	07	4.7	2.8	60	450	50	-4.0
DC4210B	07	6.8	2.9	60	450	50	-4.0
DC4211B	07	8.2	2.9	60	400	50	-4.0
DC4212B	07	10.0	3.0	60	350	50	-4.0
DC4213B	07	12.0	3.0	60	350	50	-4.0
DC4214B	07	15.0	3.1	60	300	50	-4.0
DC4215B	07	18.0	3.1	60	250	50	-4.0
DC4216B	07	22.0	3.2	60	250	50	-4.0
DC4217B	07	27.0	3.2	60	200	50	-4.0
DC4218B	07	33.0	3.2	60	200	50	-4.0
DC4224B	07	39.0	3.2	60	200	50	-4.0
DC4225B	07	47.0	3.2	60	200	50	-4.0
DC4226B	14	56.0	3.2	60	120	50	-4.0
DC4227B	14	68.0	3.2	60	120	50	-4.0
DC4228B	14	80.0	3.2	60	100	50	-4.0
DC4229D	14	80.0	3.2	100	200	50	-4.5
DC4229F	14	57.0*	3.85*	120	240	50	-15.0
DC4232B	18	100	3.2	60	200	10	-4.0
DC4233B	18	120	3.2	60	200	10	-4.0
DC4234B	18	150	3.2	60	200	10	-8.0
DC4298	10	200	3.2	100	200	25	-8.0
DC4299	10	335	3.2	100	200	25	-8.0
DC4244C	78	350	3.2	90	750	1	-4.0
Test Conditions		V = 4V f = 1MHz *V = 8V	4V to 60V f = 1MHz *4V to 85V	I _R = 10μA			

SILICON VHF/UHF
TUNING VARACTORS

TYPICAL CAPACITANCE vs. TUNING VOLTAGE

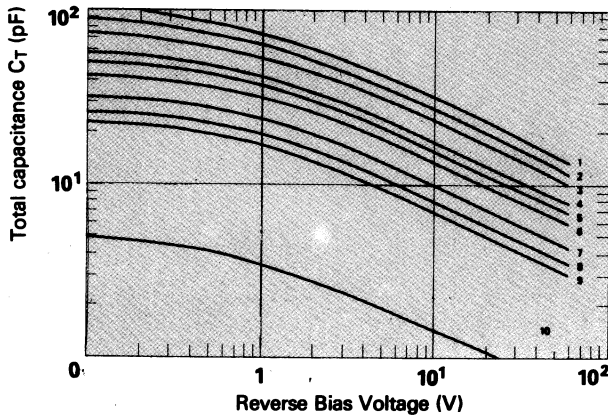

- Key: 1 DC4225B 7 DC4214B
 2 DC4224B 8 DC4213B
 3 DC4218B 9 DC4212B
 4 DC4217B 10 DC4255
 5 DC4216B
 6 DC4215B

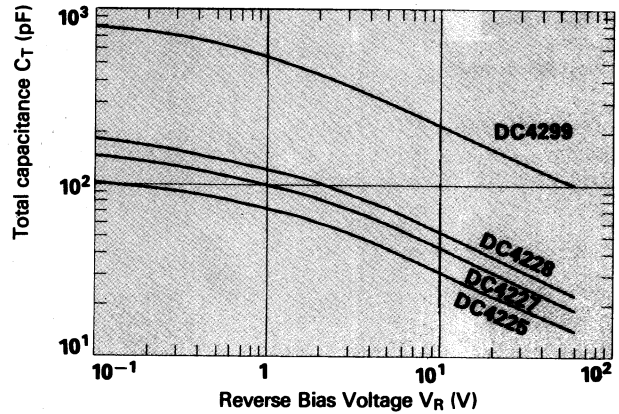

CAPACITANCE LAW

The total capacitance C_T at an applied voltage V for a varactor is given by:

$$C_T = A(V + \phi)^{-\alpha}$$

where:

A = a constant relating to epilayer doping level and diode area

ϕ = built in junction potential (0.65V for silicon)

α = 0.45 to 0.475

TYPICAL Q vs. FREQUENCY

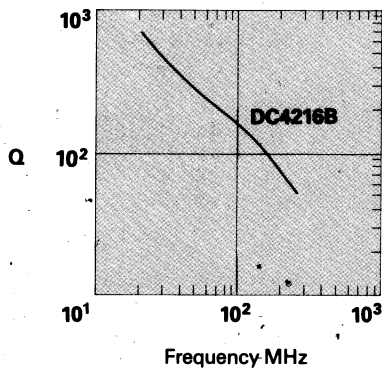

Q FACTOR

Q can be calculated from

$$Q = \frac{1}{2\pi fRC}$$

and is normally measured and specified at 50MHz for these diodes.

Q at any other frequency can be approximated by

$$Q(f_2) = \frac{f_1}{f_2} (Q(f_1))$$

TYPICAL Q vs. REVERSE BIAS VOLTAGE

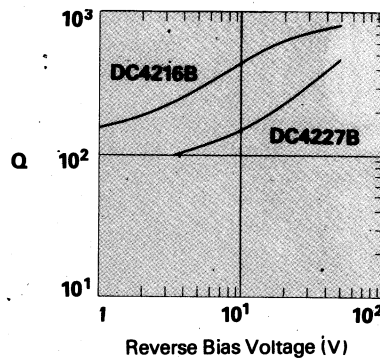

**SILICON VHF/UHF
TUNING VARACTORS**

Dimensions in mm

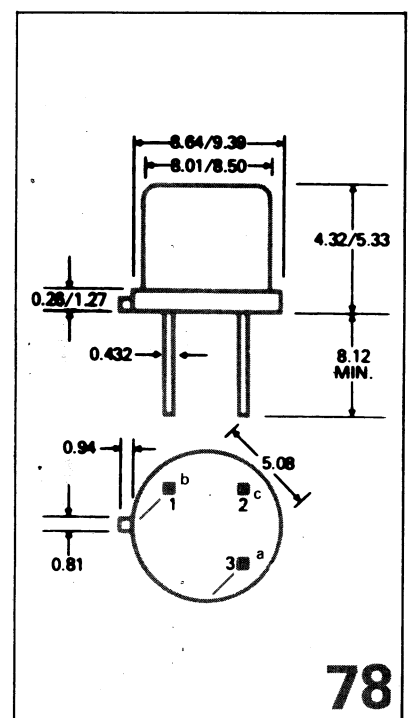
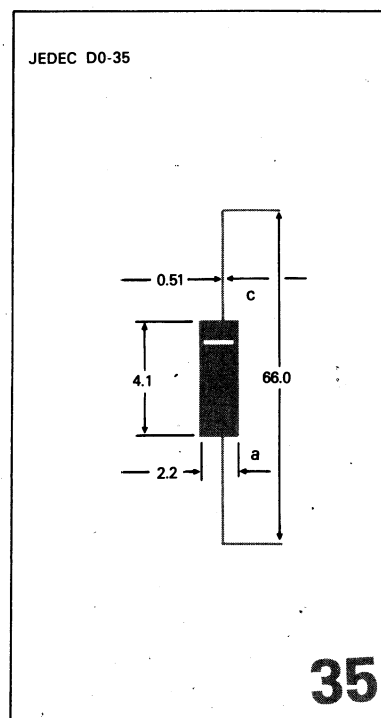
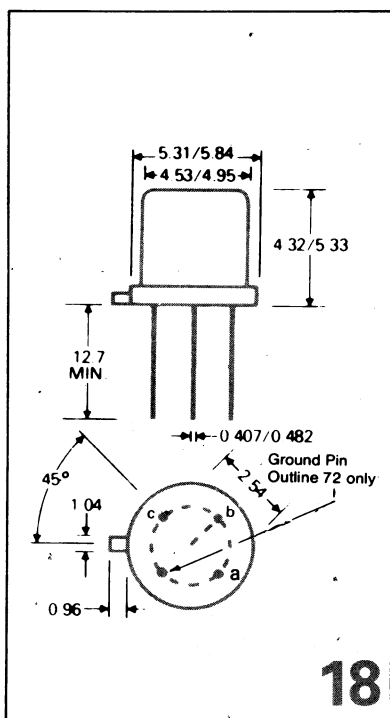
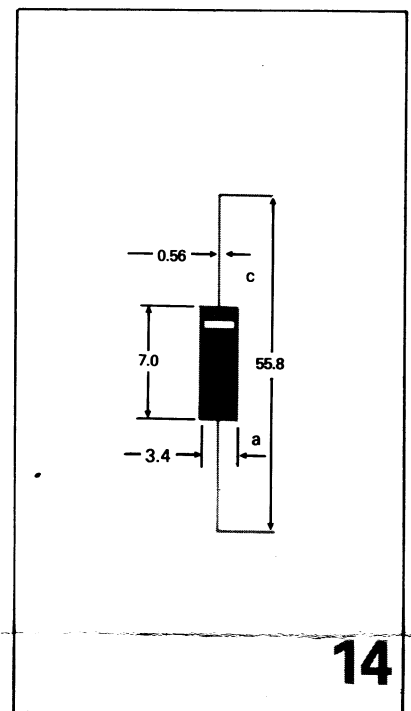
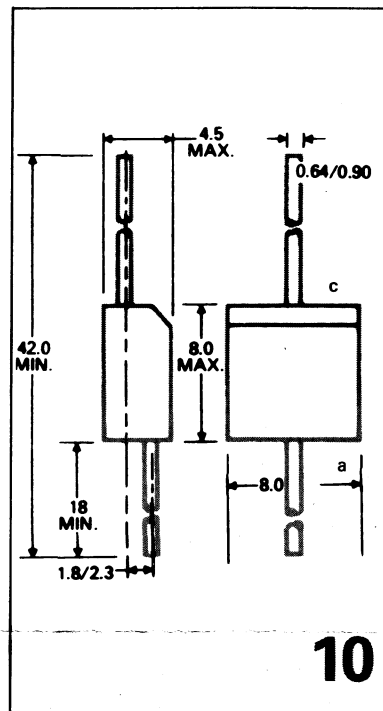
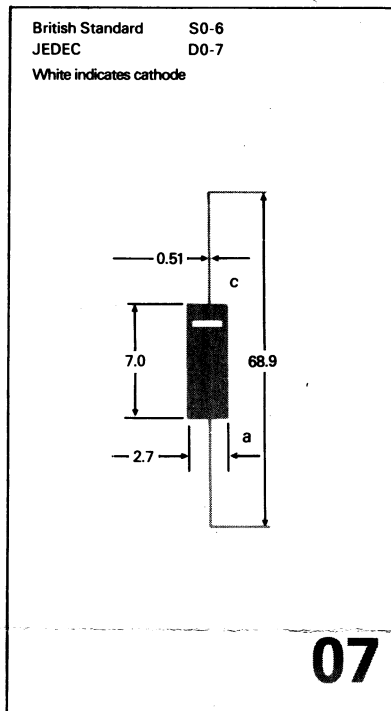

MEDL
MICROWAVE
BRITAINS BIGGEST EUROPE'S BEST

Marconi Electronic Devices Limited,
Microwave Division,
Doddington Road, Lincoln LN6 3LF, England.
Tel: 0522 688121 Telex: 56380 Fax: 0522 690916 (to 3/4/88 only)
Tel: 0522 500500 Telex: 56380 Fax: 0522 500550 (from 4/4/88 onwards)

M74
Issue 1
November '87

The information presented herein is to the best of our knowledge true and accurate. No warranty or guarantee, express or implied is made regarding the capacity, performance or suitability of any product. You are strongly urged to ensure that the information given has not been superseded by a more up-to-date version. All our products and materials are sold subject to our Conditions of Sales available on request.