

FAST RECOVERY RECTIFIER DIODES

- VERY FAST RECOVERY TIME
- HIGH SURGE CURRENT CAPABILITY
- VERY LOW FORWARD RECOVERY TIME
- VERY LOW RECOVERED CHARGE

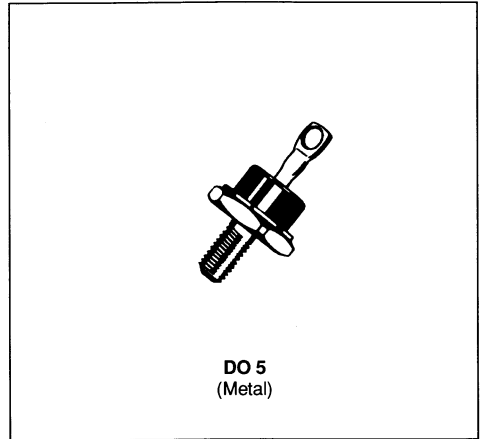

APPLICATIONS

- DC AND AC MOTOR CONTROL
- SWITCHMODE POWER SUPPLY
- HIGH FREQUENCY CHOPPERS

ABSOLUTE RATINGS (limiting values)

Symbol	Parameter		Value	Unit
I_{FRM}	Repetitive Peak Forward Current	$t_p \leq 20\mu s$	500	A
$I_F (AV)$	Average Forward Current	$T_C = 90^\circ C$	60	A
I_{FSM}	Surge non Repetitive Forward Current	$t_p = 10ms$ Sinusoidal	800	A
P_{tot}	Power Dissipation	$T_C = 90^\circ C$	110	W
T_{stg} T_j	Storage and Junction Temperature Range		- 65 to 165	$^\circ C$

Symbol	Parameter	ESM 243-					Unit
		50	100	200	300	400	
V_{RRM}	Repetitive Peak Reverse Voltage	50	100	200	300	400	V

THERMAL RESISTANCE

Symbol	Parameter	Value	Unit
$R_{th(j-c)}$	Junction-case	0.7	$^\circ C/W$

ELECTRICAL CHARACTERISTICS

STATIC CHARACTERISTICS

Symbol	Test Conditions		Min.	Typ.	Max.	Unit
I_R	$T_j = 100^\circ\text{C}$	$V_R = V_{RRM}$			10	mA
V_F	$T_j = 25^\circ\text{C}$	$I_F = 60\text{A}$			1.5	V

RECOVERY CHARACTERISTICS

Symbol	Test Conditions			Min.	Typ.	Max.	Unit
t_{rr}	$T_j = 25^\circ\text{C}$ $V_R = 30\text{V}$	$I_F = 1\text{A}$	$di_F/dt = -15\text{A}/\mu\text{s}$			100	ns
Q_{rr}	$T_j = 25^\circ\text{C}$ $V_R = 30\text{V}$	$I_F = 1\text{A}$	$di_F/dt = -15\text{A}/\mu\text{s}$			0.075	μC
I_{RM}	$T_j = 25^\circ\text{C}$ $V_R = 30\text{V}$	$I_F = 1\text{A}$	$di_F/dt = -15\text{A}/\mu\text{s}$			1.5	A

To evaluate the conduction losses use the following equations :

$$V_F = 1.15 + 0.004 I_F \quad P = 1.15 \times I_{F(AV)} + 0.004 I_F^2 (RMS)$$

PACKAGE MECHANICAL DATA

DO 5 Metal

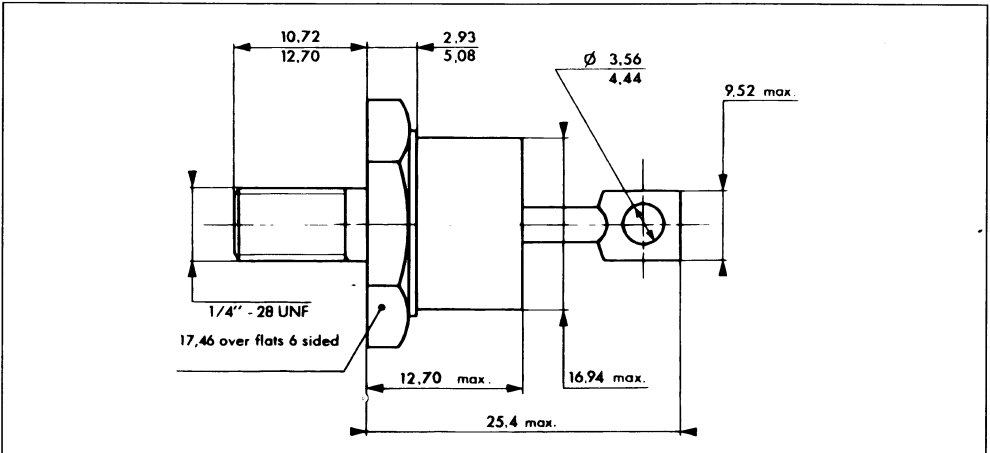

Cooling method : by conduction (method C)

Marking : Cathode connected to case : type number

Anode connected to case : type number + suffix R (consult us for these reverse version datasheets)

Weight : 18.84g

Recommended torque value : 250cm. N

Maximum torque value : 310cm. N

FAST RECOVERY RECTIFIER DIODES

- FAST RECOVERY TIME
- LOW FORWARD RECOVERY TIME
- HIGH SURGE CURRENT CAPABILITY
- AVAILABLE UP TO 600V

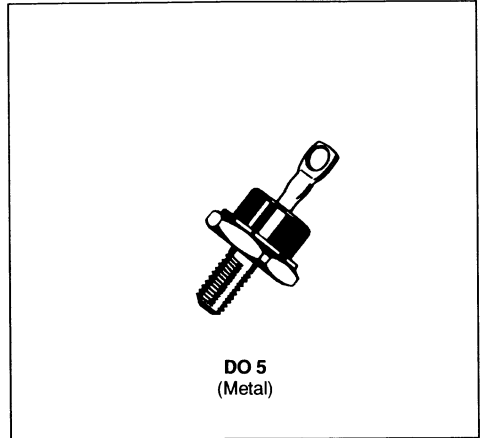
APPLICATIONS

- DC AND AC MOTOR CONTROL
- SWITCHMODE POWER SUPPLY
- HIGH FREQUENCY CHOPPERS
- HIGH FREQUENCY RECTIFIERS

ABSOLUTE RATINGS (limiting values)

Symbol	Parameter		Value	Unit
I_{FRM}	Repetitive Peak Forward Current	$t_p \leq 20\mu s$	500	A
$I_F (AV)$	Average Forward Current	$T_C = 90^\circ C$	60	A
I_{FSM}	Surge non Repetitive Forward Current	$t_p = 10ms$ Sinusoidal	800	A
P_{tot}	Power Dissipation	$T_C = 90^\circ C$	110	W
T_{stg} T_j	Storage and Junction Temperature Range		- 65 to 165	$^\circ C$

Symbol	Parameter	ESM 244-							Unit
		50	100	200	300	400	500	600	
V_{RRM}	Repetitive Peak Reverse Voltage	50	100	200	300	400	500	600	V

THERMAL RESISTANCE

Symbol	Parameter	Value	Unit
$R_{th(j-c)}$	Junction-case	0.7	$^\circ C/W$

ELECTRICAL CHARACTERISTICS

STATIC CHARACTERISTICS

Symbol	Test Conditions		Min.	Typ.	Max.	Unit
I_R	$T_j = 100^\circ\text{C}$	$V_R = V_{RRM}$			6	mA
V_F	$T_j = 25^\circ\text{C}$	$I_F = 60\text{A}$			1.5	V

RECOVERY CHARACTERISTICS

Symbol	Test Conditions			Min.	Typ.	Max.	Unit
t_{rr}	$T_j = 25^\circ\text{C}$ $V_R = 30\text{V}$	$I_F = 1\text{A}$	$di_F/dt = -15\text{A}/\mu\text{s}$			200	ns
Q_{rr}	$T_j = 25^\circ\text{C}$ $V_R = 30\text{V}$	$I_F = 1\text{A}$	$di_F/dt = -15\text{A}/\mu\text{s}$			0.3	μC
I_{RM}	$T_j = 25^\circ\text{C}$ $V_R = 30\text{V}$	$I_F = 1\text{A}$	$di_F/dt = -15\text{A}/\mu\text{s}$			3	A

To evaluate the conduction losses use the following equations :

$$V_F = 1.15 + 0.004 I_F \quad P = 1.15 \times I_{F(AV)} + 0.004 I_{F(RMS)}^2$$

PACKAGE MECHANICAL DATA

DO 5 Metal

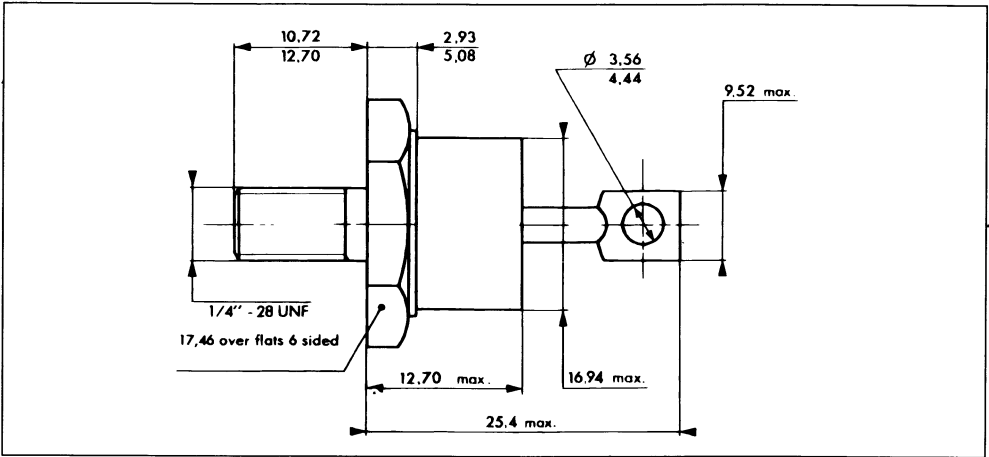

Cooling method : by conduction (method C)
 Marking : Cathode connected to case : type number
 Anode connected to case : type number + suffix R (consult us for these reverse version datasheets)
 Weight : 18.84g
 Recommended torque value : 250cm. N
 Maximum torque value : 310cm. N