

2000 Volt and 3000 Volt PIN Diodes

MA4PK2000, 3000 KILOVOLT™ Series

V 2.00

Features

- Voltage Ratings to 3000 Volts
- 25 Ampere Current Rating
- Designed for HF, Multi-Kilowatt Switches
- Low Loss, Low Distortion Design
- Rugged, Hermetically Sealed Packaging
- Convenient Solder Lug Attachment
- Low Magnetic Parts for MRI

Description

M/A-COM's KILOVOLT PIN diodes utilize modern semiconductor and packaging technology that assures low loss, low distortion, and reliable performance in multi-kilowatt switch applications at frequencies as low as 1 MHz. The semiconductor chips employed have low resistance, high power dissipation and very high stand-off voltage capability.

KILOVOLT PIN diodes employ ultra high resistivity, long carrier lifetime, float zone silicon intrinsic material onto which P+ and N+ regions are deposited using an epitaxial process specifically designed at M/A-COM for high voltage PIN diodes. This process results in better preservation of the intrinsic carrier lifetime and superior junctions in comparison to the conventional double diffused process. The processing of the I-region width is tightly controlled using modern lapping techniques.

KILOVOLT PIN diode chips utilize M/A-COM's proprietary cermachip glass passivation. The hard glass covers all exposed junction and intrinsic region surfaces. This results in a hermetically sealed, passivated chip that has been accepted in many hi-rel military programs.

Packaging

New metal-ceramic packages were developed for the KILOVOLT PIN diode series. They were designed to withstand extremely high voltages and currents and to be compatible with the semiconductor chip and RF circuitry. These packages meet the environmental requirements of MIL-STD-202 and MIL-STD750.

The PIN diode chip is bonded to the package and the anode strap is bonded to the chip at temperatures exceeding 300°C. The anode strap is a unique, large cross-section

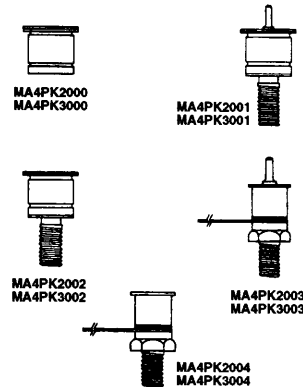

area design allowing for high current capability. The packages are sealed using a projection welding technique in an inert environment.

KILOVOLT PIN diodes are available with a solder lug on the anode electrode to allow a convenient and reliable wrap-around wire connection.

Applications

M/A-COM's KILOVOLT PIN diodes are designed for use as high power switching elements in multi-kilowatt HF and VHF applications. These PIN diodes have been extensively characterized for their electrical and thermal properties to assure predictable low loss, high power handling, and low distortion performance. Some typical applications are as follows:

1. Filter Switches
2. Antenna Couplers
3. Power Amplifier By-pass Switches
4. MRI Switches

Specifications Subject to Change Without Notice.

3-16

M/A-COM, Inc.

North America: Tel. (800) 366-2266 ■ Asia/Pacific: Tel. +81 (03) 3226-1671 ■ Europe: Tel. +44 (1344) 869 595
Fax (800) 618-8883 Fax +81 (03) 3226-1451 Fax +44 (1344) 300 020

M/A-COM KILOVOLT PIN Diodes

Part Numbers

2000 Volt Rating	3000 Volt Rating	Package Type
MA4PK2000	MA4PK3000	Pill
MA4PK2001	MA4PK3001	Stud - Solder Lug
MA4PK2002	MA4PK3002	Stud - No Solder Lug
MA4PK2003	MA4PK3003	Insulated Stud-Solder Lug
MA4PK2004	MA4PK3004	Insulated Stud-No Solder Lug

Note:
Cathode heat sink is standard on all parts. Reverse polarity, NIP diodes are available on request.

Maximum Ratings

Parameter	Absolute Max.
Operating and Storage Temp.	-65°C to +175°C
Installation Temperature	250°C, 30 Seconds
Instantaneous Reverse Voltage	Voltage Rating
Forward Current (RF and DC)	25 Amperes
Power Dissipation at 25°C Case Temperature	
MA4PK2001, MA4PK2002	50 Watts
MA4PK2003, MA4PK2004	37.5 Watts
MA4PK3001, MA4PK3002	75 Watts
MA4PK3003, MMPK3004	50 Watts

Electrical Specifications @ +25°C

Parameter	Condition	MA4PK2000 Series	MA4PK3000 Series
Reverse Voltage Rating	10 μ A	2000 Volts	3000 Volts
Series Resistance (Max)	F = 4 MHz, I = 0.5 A	0.20 Ω	0.25 Ω
Series Resistance (Typ)	F = 1.0 -100 MHz, I = 0.5 A	0.10 Ω	0.15 Ω
Total Capacitance (Max)	F = 1 MHz, V = 100 V	3.2 pF	4.0 pF
Reverse Bias	F = 10 MHz, V = 100 V	1 μ S	1 μ S
Carrier Lifetime (Min)	I _F = 10 mA	10 μ s	20 μ s
Forward Voltage (Max)	I _F = 1 A	1.2 V	1.2 V
Thermal Resistance (Max)	—	3°C/W (Stud) 4°C/W (Ins Stud)	2°C/W (Stud) 3°C/W (Ins Stud)
I-Region Width (Nom)	—	200 μ m	325 μ m

Typical Characteristics

SERIES RESISTANCE vs CURRENT FREQUENCY AT 100 MHz

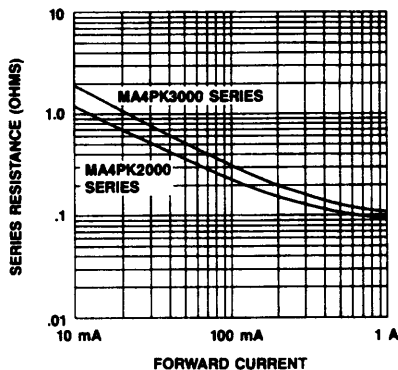

DC FORWARD VOLTAGE vs FORWARD CURRENT (MA4PK2000, MA4PK3000 SERIES)

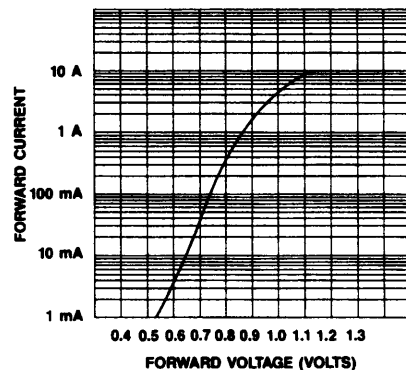

Specifications Subject to Change Without Notice.

M/A-COM, Inc.

North America: Tel. (800) 366-2266 Asia/Pacific: Tel. +81 (03) 3226-1671 Europe: Tel. +44 (1344) 869 595
 Fax (800) 618-8883 Fax +81 (03) 3226-1451 Fax +44 (1344) 300 020

Typical Characteristics (Cont'd)

REVERSE BIAS CAPACITANCE vs FREQUENCY AND REVERSE VOLTAGE (MA4PK2000 SERIES)

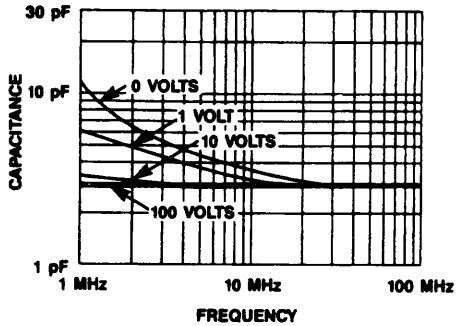

REVERSE BIAS CAPACITANCE vs FREQUENCY AND REVERSE VOLTAGE (MA4PK3000 SERIES)

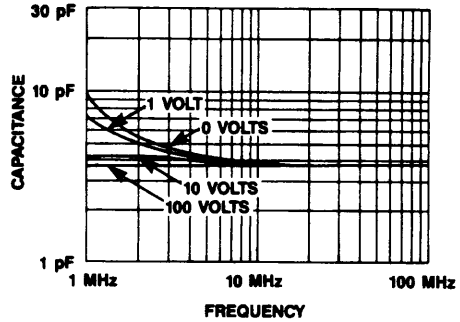

REVERSE BIAS CONDUCTANCE vs FREQUENCY AND REVERSE VOLTAGE (MA4PK2000 SERIES)

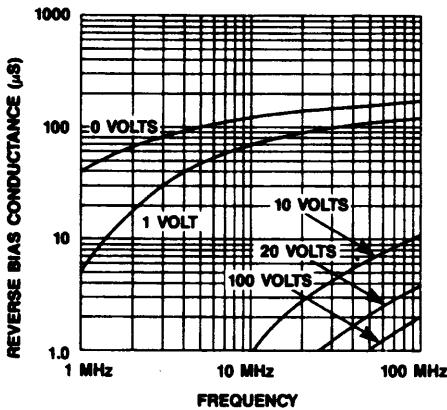

REVERSE BIAS CONDUCTANCE vs FREQUENCY AND REVERSE VOLTAGE (MA4PK3000 SERIES)

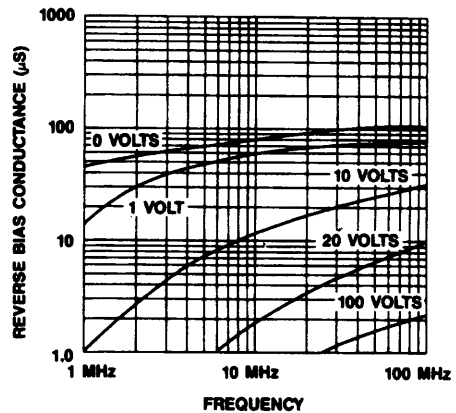

CARRIER LIFETIME vs FORWARD CURRENT

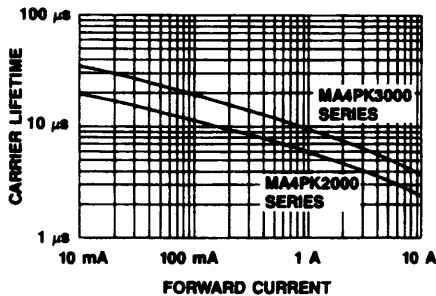

PULSED THERMAL IMPEDANCE

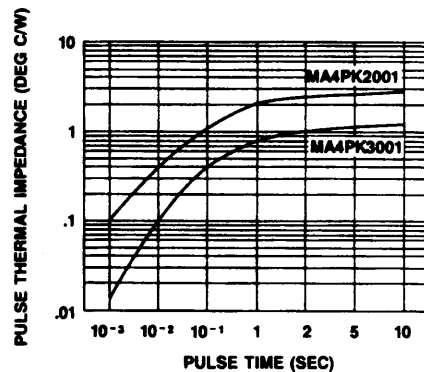

Specifications Subject to Change Without Notice.

Case Styles ● Denotes Cathode

Pill

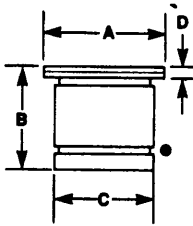

MA4PK2000 Case Style 1027

DIM.	INCHES		MILLIMETERS	
	MIN.	MAX.	MIN.	MAX.
A	0.304	0.316	7.72	8.02
B	0.254	0.270	6.45	6.86
C	0.245	0.255	6.22	6.48
D	0.023	0.031	0.58	0.79

C_p = .45 pF
L_S = 2 nH

MAPK3000 Case Style 1073

DIM.	INCHES		MILLIMETERS	
	MIN.	MAX.	MIN.	MAX.
A	0.468	0.485	11.9	12.3
B	0.373	0.395	9.45	10.0
C	0.390	0.400	9.91	10.2
D	0.028	0.042	0.71	1.06

C_p = .75 pF
L_S = 3 nH

Stud

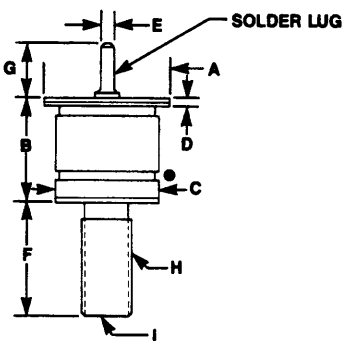

MA4PK2001
Case Style 1082
(Solder Lug)

DIM.	INCHES		MILLIMETERS	
	MIN.	MAX.	MIN.	MAX.
A	0.304	0.316	7.72	8.02
B	0.266	0.292	6.45	6.86
C	0.245	0.255	6.22	6.48
D	0.023	0.031	0.58	0.79
E	0.060	0.065	1.52	1.65
F	0.281	0.305	7.14	7.75
G	0.190	0.205	4.83	5.21
H	6-40 UNF-3A			
I	.072 SPLINE x .07 DP			

C_p = .45 pF
L_S = 2 nH

MA4PK2002
Case Style 1048
(No Solder Lug)

MA4PK3001
Case Style 11084
(Solder Lug)

DIM.	INCHES		MILLIMETERS	
	MIN.	MAX.	MIN.	MAX.
A	0.468	0.485	11.9	12.3
B	0.387	0.411	9.83	10.4
C	0.390	0.400	9.90	10.1
D	0.028	0.042	0.71	1.06
E	0.060	0.065	1.52	1.65
F	0.425	0.445	10.8	11.3
G	0.190	0.205	4.83	5.21
H	10-32 UNF-2A			
I	.050 SLOT x .06 DP			

C_p = .75 pF
L_S = 3 nH

MA4PK3002
Case Style 1074
(No Solder Lug)

Insulated Stud

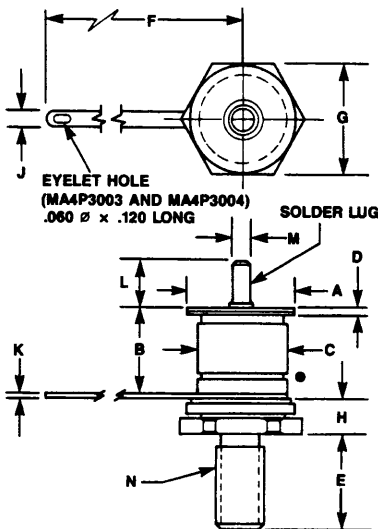

MA4PK2003
Case Style 1080
(Solder Lug)

DIM.	INCHES		MILLIMETERS	
	MIN.	MAX.	MIN.	MAX.
A	0.304	0.316	7.72	8.02
B	0.254	0.270	6.45	6.86
C	0.245	0.255	6.22	6.48
D	0.023	0.031	0.58	0.79
E	0.221	0.252	5.61	6.40
F	0.780	0.790	19.8	20.1
G	0.245	0.255	6.22	6.48
H	0.128	0.137	3.25	3.48
J	0.120	0.130	3.05	3.30
K	0.007	0.009	0.18	0.23
L	0.190	0.205	4.83	5.21
M	0.060	0.065	1.52	1.65
N	6-32 UNC-3A			

C_p = .45 pF
L_S = 2 nH
C_{GRD} = 1.1 pF

MA4PK2004
Case Style 1038
(No Solder Lug)

MA4PK3003
Case Style 1085
(Solder Lug)

DIM.	INCHES		MILLIMETERS	
	MIN.	MAX.	MIN.	MAX.
A	0.468	0.485	11.9	12.3
B	0.373	0.395	9.47	10.0
C	0.390	0.400	9.91	10.2
D	0.028	0.042	0.71	1.07
E	0.422	0.452	10.7	11.5
F	0.805	0.820	20.4	20.8
G	0.490	0.500	12.4	12.7
H	0.148	0.170	3.76	4.32
J	0.120	0.130	3.05	3.30
K	0.022	0.026	0.559	0.660
L	0.190	0.205	4.83	5.21
M	0.060	0.065	1.52	1.65
N	10-32 UNF-2A			

C_p = .75 pF
L_S = 3 nH
C_{GRD} = 4.2 pF

MA4PK3004
Case Style 1075
(No Solder Lug)

Specifications Subject to Change Without Notice.

M/A-COM, Inc.

North America: Tel. (800) 366-2266
Fax (800) 618-8883

Asia/Pacific: Tel. +81 (03) 3226-1671
Fax +81 (03) 3226-1451

Europe: Tel. +44 (1344) 869 595
Fax +44 (1344) 300 020