

FEATURES

- **HIGH GAIN BANDWIDTH PRODUCT:** $f_r = 2.5$ GHz
- **PNP COMPLEMENT TO THE NE74014**
- **LOW OUTPUT CAPACITANCE:** $C_{OB} = 2.1$ pF

DESCRIPTION AND APPLICATIONS

The NE901 Series of PNP silicon epitaxial transistors is designed for high frequency amplifier and high speed switching applications. The series has high voltage and current handling capabilities providing good dynamic range. The device is available in chip form and in a hermetically sealed package (TO-33).

PERFORMANCE SPECIFICATIONS ($T_A = 25^\circ\text{C}$)

PART NUMBER EIAJ ¹ REGISTERED NUMBER PACKAGE OUTLINE			NE90115 2SA1224 15		
SYMBOLS	PARAMETERS AND CONDITIONS	UNITS	MIN	TYP	MAX
f_r	Gain Bandwidth Product at $V_{CE} = -10$ V, $I_c = 50$ mA	GHz		2.5	
MAG	Maximum Available Gain at $V_{CE} = -10$ V, $I_c = 10$ mA $f = 500$ MHz	dB		11	
t_D	See Test Circuits	η_s		3.5	
t_r		η_s		4.1	
t_f		η_s		3.2	

Note:

1. Electronic Industrial Association of Japan.

ELECTRICAL CHARACTERISTICS ($T_A = 25^\circ\text{C}$)

PART NUMBER EIAJ ¹ REGISTERED NUMBER PACKAGE OUTLINE			NE90115 2SA1224 15		
SYMBOLS	PARAMETERS AND CONDITIONS	UNITS	MIN	TYP	MAX
I_{CBO}	Collector Cutoff Current at $V_{CB} = -20$ V, $I_E = 0$	μA			-0.1
I_{EBO}	Emitter Cutoff Current at $V_{EB} = -2$ V, $I_C = 0$	μA			-0.1
$V_{CE(SAT)}$	Collector Saturation Voltage ² at $I_c = -100$ mA, $I_b = -10$ mA	V		-0.23	-0.6
$V_{BE(SAT)}$	Base Saturation Voltage ² at $I_c = -100$ mA, $I_b = -10$ mA	V		-0.89	-1.2
h_{FE}	DC Current Gain ² at $V_{CE} = -10$ V, $I_c = -50$ mA		20	75	200
C_{CB}	Collector to Base Capacitance ³ at $V_{CB} = -10$ V, $I_E = 0$ mA, $f = 1$ MHz	pF		2.1	4
R_{TH}	Thermal Resistance (Junction-to-Case)	$^\circ\text{C/W}$			35
P_T	Total Device Dissipation	mW			800

Notes:

1. Electronic Industrial Association of Japan.
2. Pulsed. $PW \leq 350$ μs duty cycle $\leq 2\%$.
3. The Emitter is grounded.

ABSOLUTE MAXIMUM RATINGS ($T_A = 25^\circ\text{C}$)

SYMBOLS	PARAMETERS	UNITS	RATINGS
Vcbo	Collector to Base Voltage	V	-40
Vceo	Collector to Emitter Voltage	V	-25
Vebo	Emitter to Base Voltage	V	-3
Ic	Collector Current	mA	-250
Tj	Junction Temperature	°C	200
Tstg	Storage Temperature	°C	-65 to +200

OUTLINE DIMENSIONS (Units in mm)

NE90100 (CHIP)
(Chip Thickness: 140 μm to 160 μm)

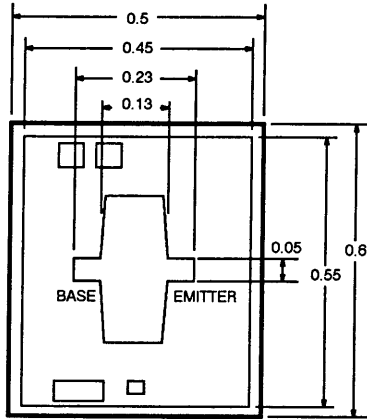

OUTLINE 15

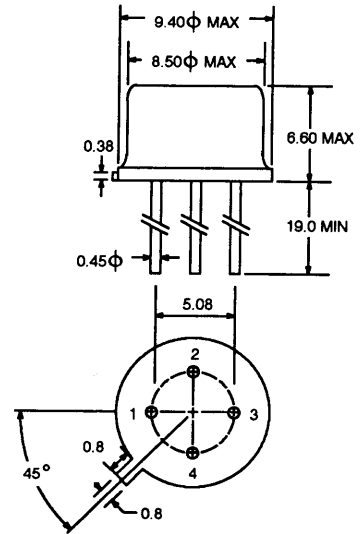

SWITCHING TIME TEST CIRCUITS

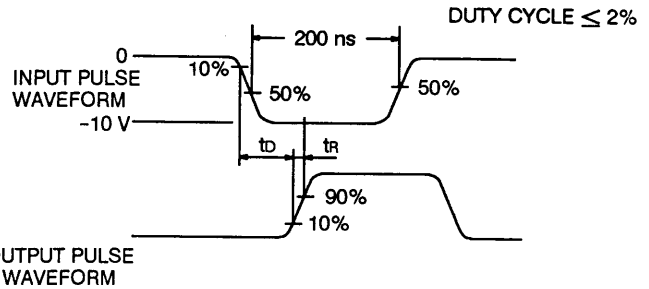
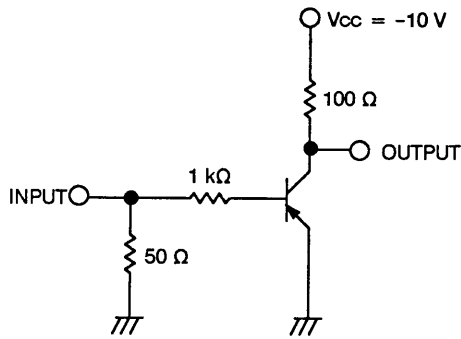

td, tr TEST CIRCUIT

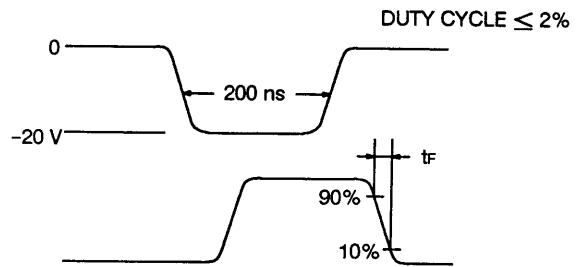
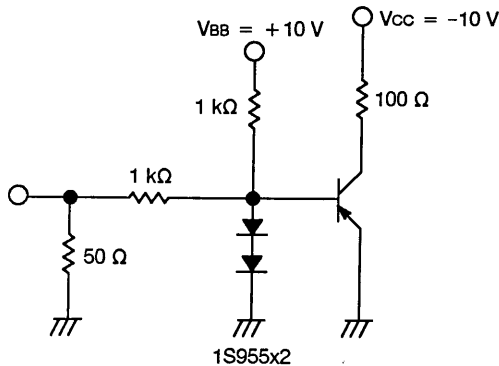

tf TEST CIRCUIT

TYPICAL PERFORMANCE CHARACTERISTICS (TA = 25°C)

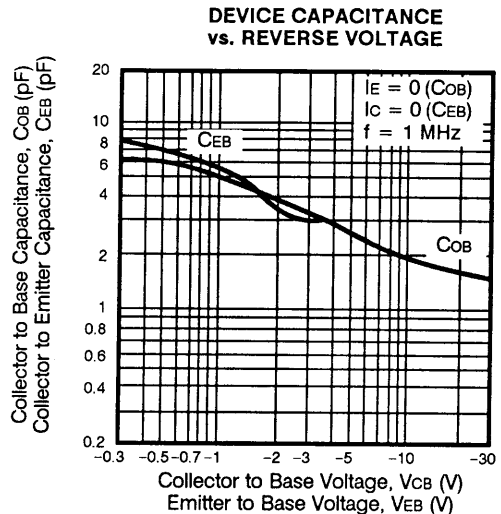
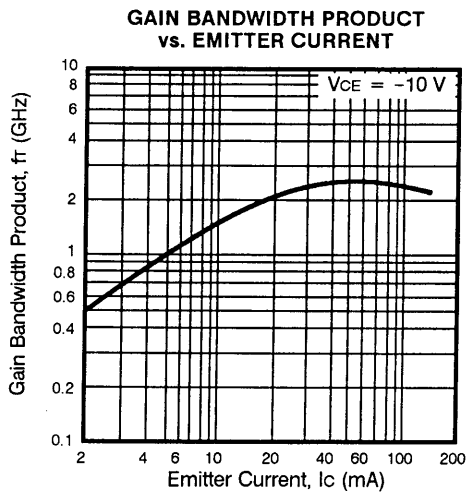
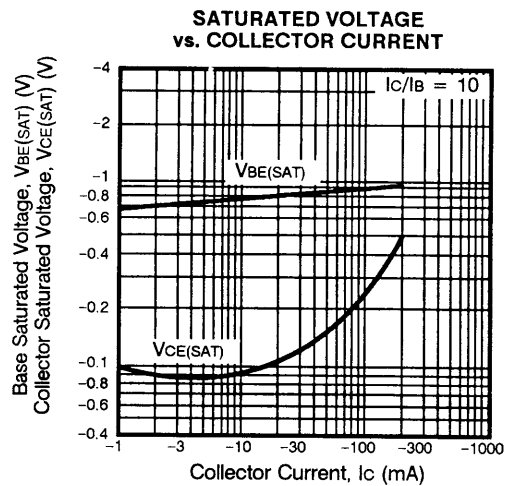
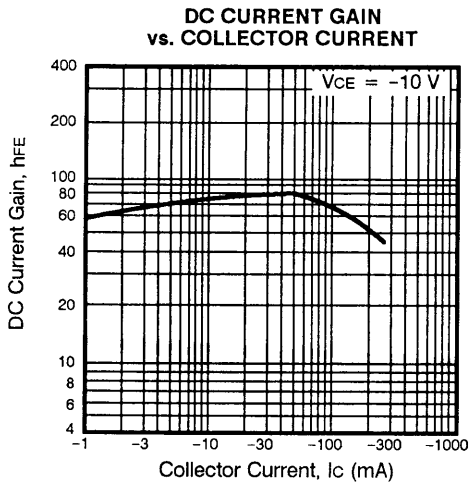
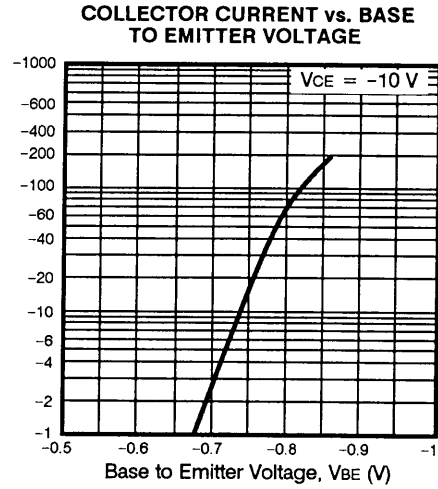
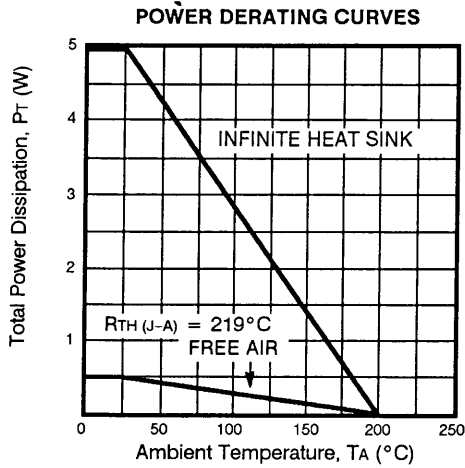

TYPICAL COMMON EMITTER SCATTERING PARAMETERS

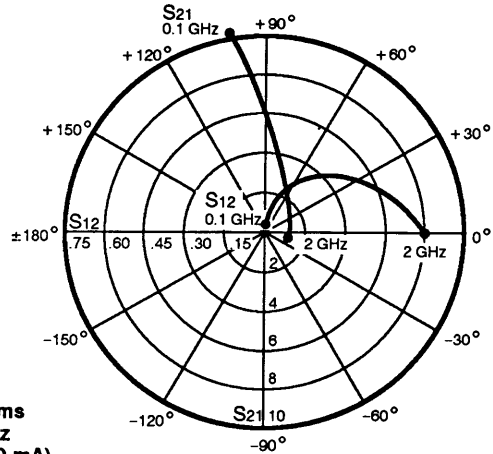
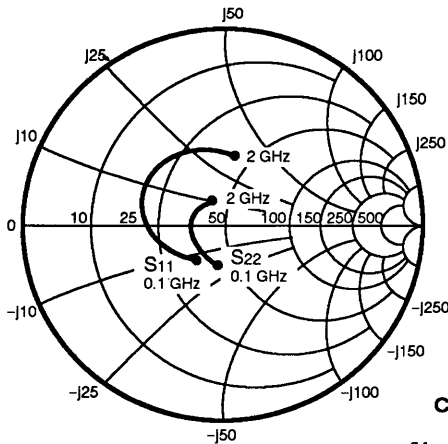

NE90115
Coordinates in Ohms
Frequency in GHz
(VCE = -10 V, IC = 50 mA)

S-MAGN AND ANGLES:

VCE = -10 V, IC = 10 mA

FREQUENCY (MHz)	S11		S21		S12		S22	
100	.32	-101	8.16	105	.03	51	.37	-55
200	.31	-128	4.48	91	.07	58	.25	-60
400	.37	-154	2.55	74	.12	61	.20	-73
600	.41	-170	1.86	59	.18	58	.22	-90
800	.44	175	1.52	45	.23	53	.23	-109
1000	.46	162	1.34	32	.29	47	.26	-126
1200	.47	147	1.21	20	.34	39	.26	-143
1400	.47	133	1.11	9	.40	32	.27	-160
1600	.46	119	1.04	-1	.46	24	.27	-176
1800	.44	103	1.00	-11	.52	16	.25	-167
2000	.42	84	0.99	-20	.59	8	.22	150

VCE = -10 V, IC = 25 mA

100	.23	-118	9.77	101	.03	62	.24	-79
200	.25	-139	5.26	89	.07	70	.14	-92
400	.32	-159	2.91	73	.13	67	.11	-109
600	.37	-174	2.11	59	.20	60	.13	-122
800	.40	173	1.71	46	.26	53	.15	-138
1000	.42	160	1.50	34	.32	44	.17	-149
1200	.42	146	1.34	23	.37	35	.18	-165
1400	.43	132	1.24	12	.42	27	.18	180
1600	.41	119	1.16	0	.48	19	.18	167
1800	.39	102	1.12	-9	.53	11	.16	150
2000	.36	83	1.10	-19	.59	2	.13	133

VCE = -10 V, IC = 50 mA

100	.20	-129	10.29	99	.02	68	.20	-94
200	.24	-145	5.50	88	.07	73	.12	-115
400	.31	-163	3.03	73	.14	69	.10	-137
600	.36	-176	2.17	59	.21	61	.11	-143
800	.39	171	1.76	46	.27	52	.14	-156
1000	.40	159	1.53	34	.33	43	.15	-165
1200	.41	144	1.37	23	.38	34	.16	-180
1400	.42	131	1.27	12	.44	26	.16	166
1600	.40	118	1.19	1	.49	17	.15	154
1800	.37	101	1.15	-9	.53	8	.13	135
2000	.34	82	1.14	-19	.59	-0	.11	116

VCE = -10 V, IC = 75 mA

100	.20	-136	10.24	98	.02	69	.18	-100
200	.25	-149	5.45	87	.07	74	.12	-121
400	.32	-166	3.00	72	.14	69	.10	-144
600	.36	-178	2.15	59	.21	60	.11	-149
800	.39	170	1.74	46	.27	52	.13	-160
1000	.41	157	1.51	33	.33	43	.15	-168
1200	.41	144	1.36	23	.39	33	.15	177
1400	.42	130	1.25	12	.44	25	.15	163
1600	.40	117	1.19	1	.49	16	.14	151
1800	.37	101	1.14	-9	.54	8	.12	133
2000	.35	81	1.13	-19	.59	-1	.10	112

