

LINEAR INTEGRATED CIRCUIT

PRELIMINARY DATA

12V VOLTAGE REGULATOR

- OUTPUT CURRENT > 500 mA
- TIGHT TOLERANCE for OUTPUT VOLTAGE
- LOAD REGULATION LESS THAN 1%
- RIPPLE REJECTION 60 dB TYPICAL
- LOW OUTPUT IMPEDANCE
- EXCELLENT TRANSIENT RESPONSE
- HIGH TEMPERATURE STABILITY

The L130 is a silicon monolithic voltage regulator in Jedec TO-126 plastic package which can supply more than 500 mA. It incorporates the following functions :

- internal overload protection
- short-circuit protection.

The L130 can be used for voltage regulation in consumer and industrial applications.

ABSOLUTE MAXIMUM RATINGS

V_i	Input supply voltage	27	V
P_{tot}	Total power dissipation at $T_{amb} = 25^\circ\text{C}$	1.25	W
	at $T_{case} = 25^\circ\text{C}$	14	W
T_{stg}	Storage temperature	-55 to 125	$^\circ\text{C}$
T_j	Junction temperature	150	$^\circ\text{C}$
T_{op}	Operating temperature	-20 to 85	$^\circ\text{C}$

ORDERING NUMBER : L 130

MECHANICAL DATA

Dimensions in mm

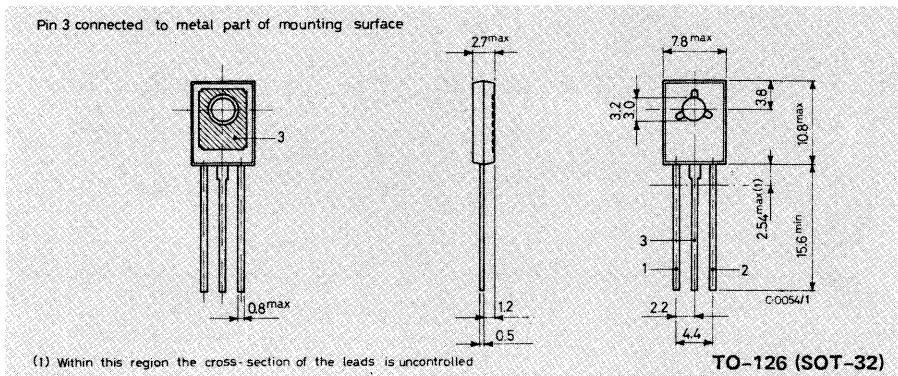

L 130

BLOCK DIAGRAM

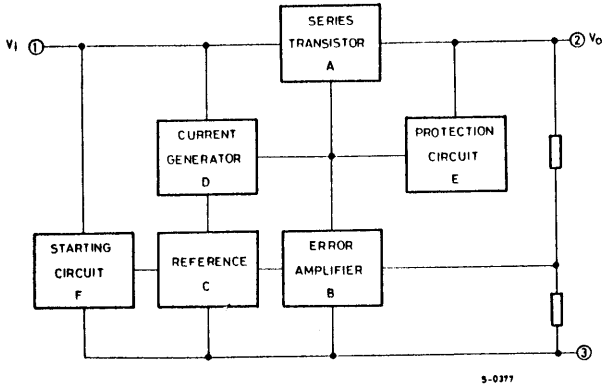

SCHEMATIC DIAGRAM

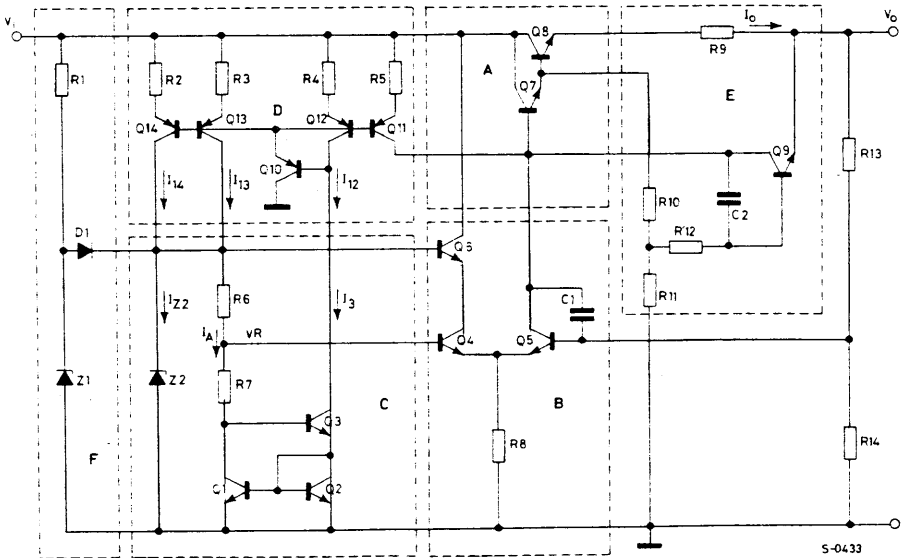

L 130

TEST CIRCUIT with output characteristic

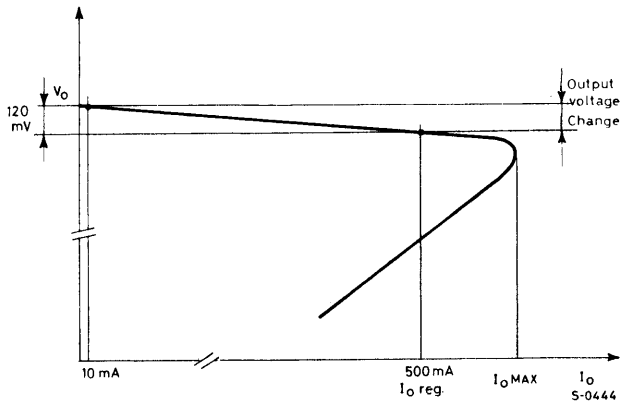
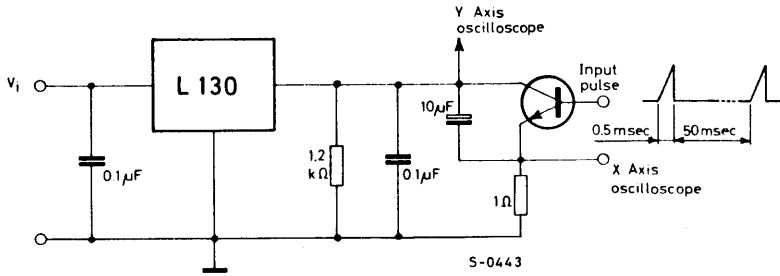

THERMAL DATA

$R_{th \text{ j-case}}$	Thermal resistance junction-case	max	9 °C/W
$R_{th \text{ j-amb}}$	Thermal resistance junction-ambient	max	100 °C/W

L 130

ELECTRICAL CHARACTERISTICS

($T_j = 25^\circ\text{C}$, $V_i = 21\text{ V}$ unless otherwise specified)

Parameter	Test conditions	Min.	Typ.	Max.	Unit
V_o Output voltage	$14.5\text{V} \leq V_i \leq 27\text{V}$ $I_o = 10\text{mA}$ $C_L = 10\ \mu\text{F}$	11.4	12	12.6	V
ΔV_o^* Load regulation	$I_o = 10$ to 500mA $C_L = 10\ \mu\text{F}$		0.3	1	%V
I_o^* Regulated output current	$\frac{\Delta V_o}{V_o} \leq 1\%$	500	720		mA
$I_o\text{ MAX}^*$ Maximum output current	$T_{\text{case}} = 25^\circ\text{C}$ $T_{\text{case}} = 85^\circ\text{C}$		0.75 0.8	1	A A
I_{sc} Output short-circuit current	$V_o = 0$		100	200	mA
I_d Quiescent drain current	$V_i = 27\text{V}$ $I_o = 0$		10		mA
ΔV_o Line regulation	$V_i = 14.5$ to 21V $I_o = 10\text{mA}$ $C_L = 10\ \mu\text{F}$		6	33	mV
$\frac{\Delta V_o}{\Delta T_{\text{amb}}}$ Temperature coefficient	$I_o = 10\text{mA}$ $C_L = 10\ \mu\text{F}$ $T_{\text{amb}} = -20$ to 85°C		1.2		mV/ $^\circ\text{C}$
e_N Output noise voltage	$I_o = 10\text{mA}$ $C_L^{**} = 20\ \mu\text{F}$ B = 10 Hz to 100 kHz		150		μV
R_o Output resistance	$I_o = 500\text{mA}$		20		m Ω
SVR Supply voltage rejection	$V_i = 19\text{V}$ $I_o = 10\text{mA}$ $\Delta V_i = 4\text{V}$ peak to peak f = 100 Hz $C_L = 10\ \mu\text{F}$	46	60		dB

* Refer to the test circuit.

** Tantalum capacitor.

Typical output voltage versus output current

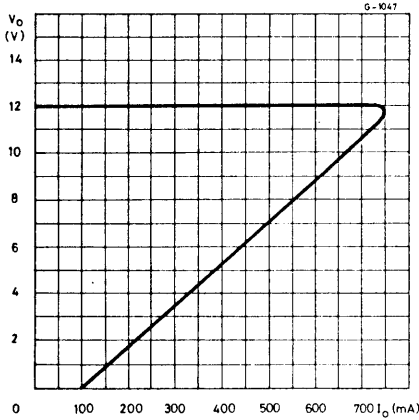

Power rating chart

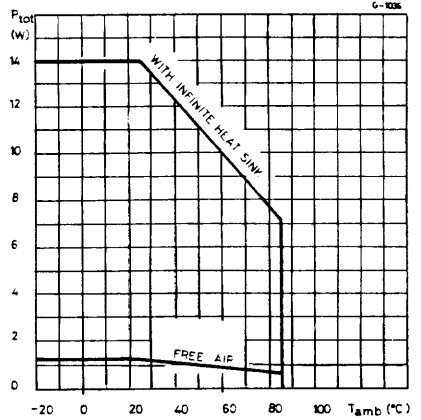

Typical regulated output current versus junction temperature

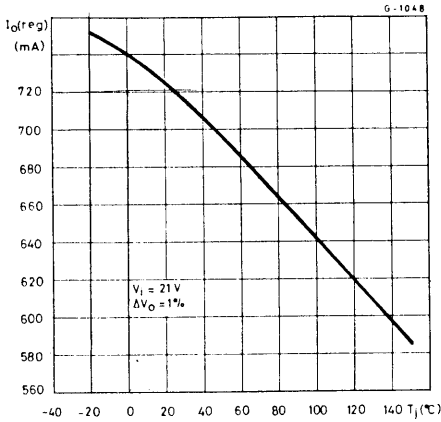

Maximum output current versus junction temperature

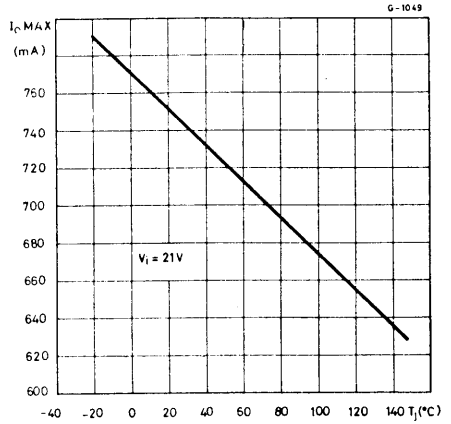

L 130

Typical dropout voltage versus junction temperature

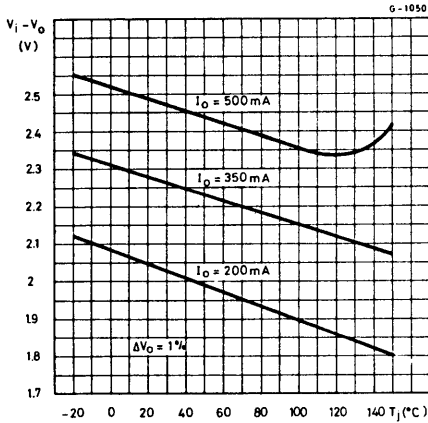

Typical short-circuit current versus input voltage

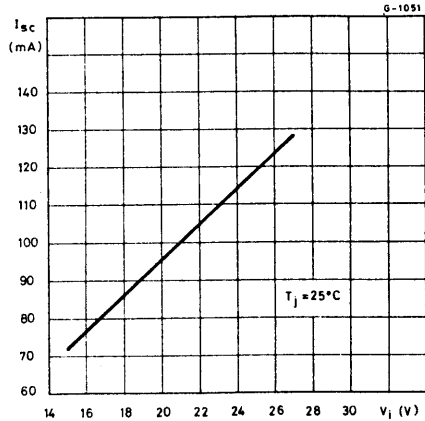

Typical short-circuit current versus junction temperature

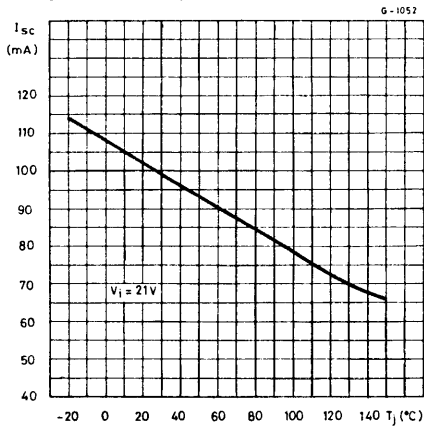

Typical quiescent drain current versus junction temperature

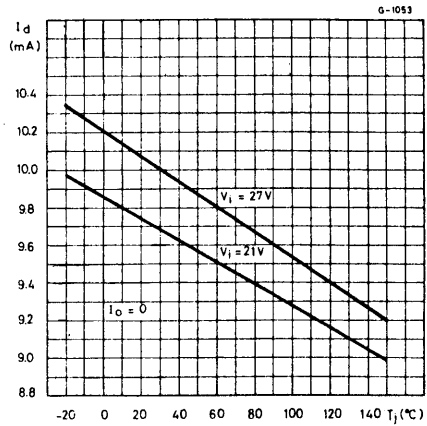

Typical quiescent drain current variation versus junction temperature

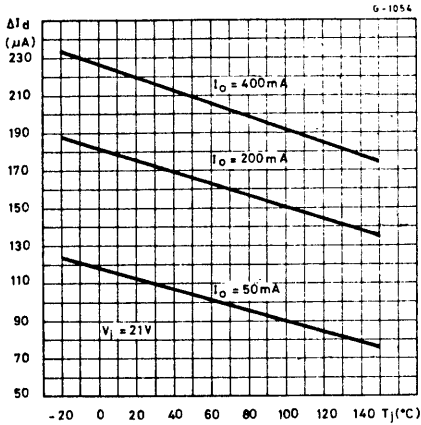

Typical supply voltage rejection versus frequency

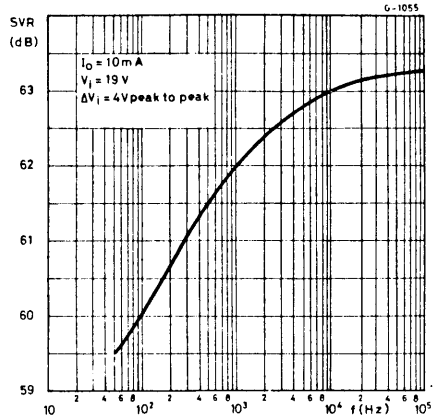

Typical supply voltage rejection versus regulated output current

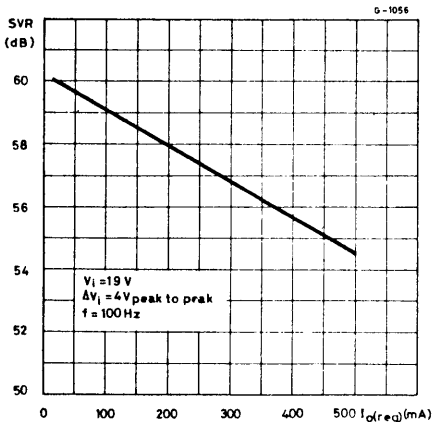

Typical output resistance versus frequency

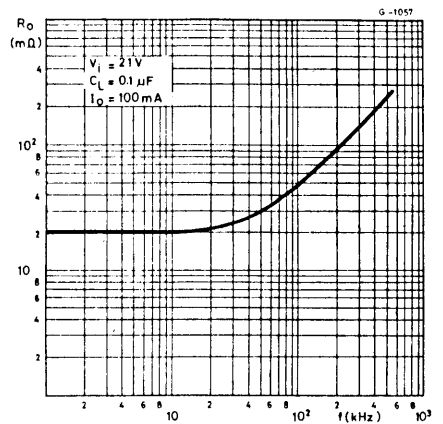

L 130

Typical line transient response

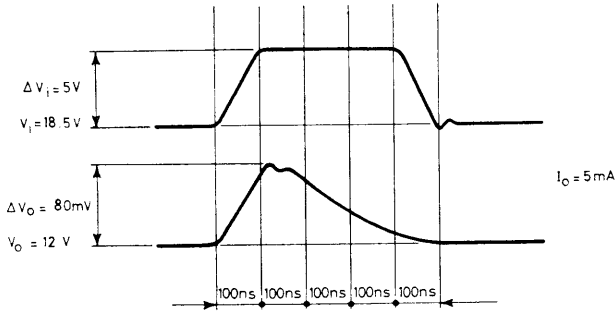

S-0445

APPLICATION INFORMATION

Typical connection circuit

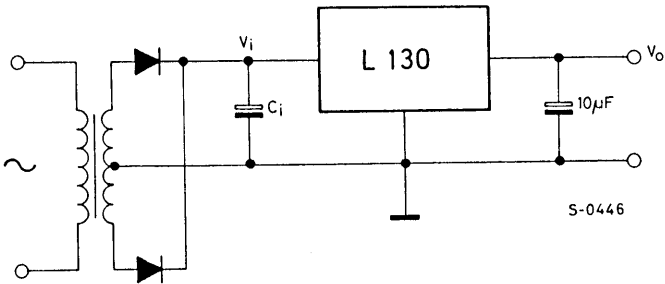

S-0446

APPLICATION INFORMATION (continued)

Negative output voltage circuit.

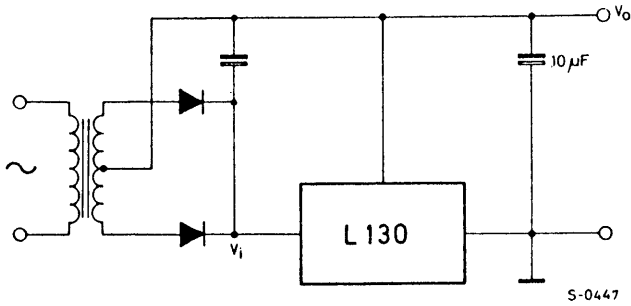

Parallel connected voltage regulators and its output characteristics.

