

FEATURES

- *Guaranteed* Operation at +1.2V Op Amp and Reference on Single Chip
- Low Supply Current 400 μ A
- Capable of Floating Mode Operation
- Low Reference Drift 20ppm/ $^{\circ}$ C
- Low Offset Voltage
- Output Swings to Within 15mV of Rails

APPLICATIONS

- Remote Signal Conditioner/Transmitter
- Battery Operated Instruments
- Precision Current Regulators
- Precision Voltage Regulators
- Thermocouple Transmitter

DESCRIPTION

The LM10 combines a precision reference, a reference buffer amplifier and an independent, high quality op amp on a single chip. The device is capable of operation from a single supply as low as 1.1V, from dual supplies up to ± 20 V and typically draws 270 μ A supply current. Input voltage range for the op amp includes ground, while the unloaded output can swing to within 15mV of each rail. Further, the LM10 will deliver 20mA output current and still swing within ± 400 mV of the supply rails.

With its low operating current and floating operation capability, the LM10 is ideal for two wire analog transmitter circuits where the processed signal is carried on the same line used for power. The LM10 is suggested for portable battery powered equipment and is fully specified for operation from a single 1.2V battery. Other applications include precision current and voltage regulators, operating from very low voltages to several hundred volts.

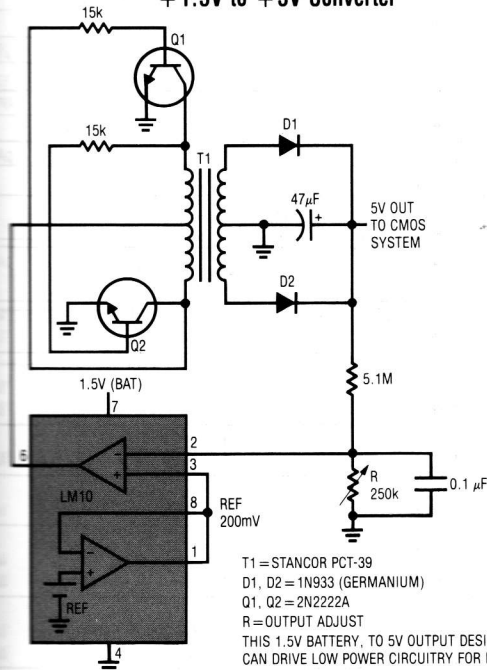
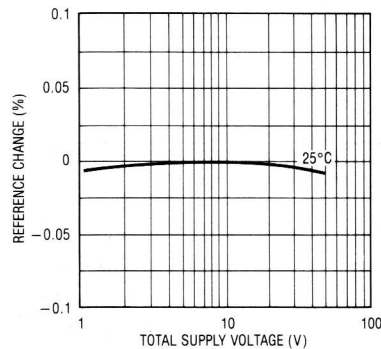
+ 1.5V to +5V Converter

Line Regulation

ABSOLUTE MAXIMUM RATINGS

Total Supply Voltage
 LM10/LM10B/LM10C 45V
 LM10BL/LM10CL 7V

Differential Input Voltage (Note 1)
 LM10/LM10B/LM10C ±40V
 LM10BL/LM10CL ±7V

Output Short Circuit Duration Indefinite

Operating Temperature Range (Note 2)
 LM10 $-55^{\circ}\text{C} \leq T_A \leq 125^{\circ}\text{C}$
 LM10B/LM10BL $-25^{\circ}\text{C} \leq T_A \leq 85^{\circ}\text{C}$
 LM10C/LM10CL $0^{\circ}\text{C} \leq T_A \leq 70^{\circ}\text{C}$

Storage Temperature Range $-65^{\circ}\text{C} \leq T_A \leq 150^{\circ}\text{C}$

Lead Temperature (Soldering, 10 sec.) 300°C

PACKAGE/ORDER INFORMATION

	ORDER PART NUMBER
<p>TOP VIEW REFERENCE FEEDBACK REFERENCE OUTPUT OP AMP INPUTS OP AMP OUTPUT BALANCE V- V+ METAL CAN H PACKAGE</p>	LM10H LM10BH LM10CH LM10BLH LM10CLH
<p>TOP VIEW REFERENCE FEEDBACK REFERENCE OUTPUT OP AMP INPUT (-) OP AMP INPUT (+) V- V+ OP AMP OUTPUT BALANCE J8 HERMETIC PACKAGE N8 PLASTIC DIP PACKAGE</p>	LM10CN8 LM10CLN8 LM10CJ8 LM10CLJ8 LM10J8 LM10BJ8 LM10BLJ8

OP AMP ELECTRICAL CHARACTERISTICS (Note 3)

SYMBOL	PARAMETER	CONDITIONS	LM10/LM10B			LM10C			UNITS	
			MIN	TYP	MAX	MIN	TYP	MAX		
V_{OS}	Input Offset Voltage		0.3	2.0	3.0	0.5	4.0	5.0	mV mV	
$\frac{\Delta V_{OS}}{\Delta \text{Temp}}$	Average Offset Voltage Drift		2.0			5.0			$\mu\text{V}/^{\circ}\text{C}$	
I_{OS}	Input Offset Current	(Note 4)	0.25	0.7	1.5	0.4	2.0	3.0	nA nA	
$\frac{\Delta I_{OS}}{\Delta \text{Temp}}$	Offset Current Drift		2.0			5.0			$\text{pA}/^{\circ}\text{C}$	
I_B	Input Bias Current		10	20	30	12	30	40	nA nA	
$\frac{\Delta I_B}{\Delta \text{Temp}}$	Bias Current Drift		60			90			$\text{pA}/^{\circ}\text{C}$	
A_{VOL}	Large Signal Voltage Gain	$V_S = \pm 20\text{V}, I_{OUT} = 0, V_{OUT} = \pm 19.95\text{V}$	120	400	80	400			V/mV V/mV	
		$V_S = \pm 20\text{V}, V_{OUT} = \pm 19.4\text{V}$ $I_{OUT} = \pm 20\text{mA}$ $I_{OUT} = \pm 15\text{mA}$	50	130	20	25	130	15		V/mV V/mV
		$V_S = \pm 0.6\text{V}, I_{OUT} = \pm 2\text{mA}$ $V_{OUT} = \pm 0.4\text{V}, V_{CM} = -0.4\text{V}$	1.5	3.0		1.0	3.0			V/mV
		$V_S = \pm 0.65\text{V}, I_{OUT} = \pm 2\text{mA}$ $V_{OUT} = \pm 0.3\text{V}, V_{CM} = -0.4\text{V}$	0.5			0.75				V/mV
	Shunt Gain (Note 5)	$0.1\text{mA} \leq I_{OUT} \leq 5\text{mA}, R_L = 1.1\text{k}\Omega$ $1.2\text{V} \leq V_{OUT} \leq 40\text{V}$ $1.3\text{V} \leq V_{OUT} \leq 40\text{V}$	14	33	6	10	33	6	V/mV V/mV	
		$0.1\text{mA} \leq I_{OUT} \leq 20\text{mA}, R_L = 250\Omega$ $1.5\text{V} \leq V^+ \leq 40\text{V}$	8	25	4	6	25	4	V/mV V/mV	
			4			4				

OP AMP ELECTRICAL CHARACTERISTICS (Note 3)

SYMBOL	PARAMETER	CONDITIONS	LM10/LM10B			LM10C			UNITS
			MIN	TYP	MAX	MIN	TYP	MAX	
CMRR	Common-Mode Rejection Ratio	$V_S = \pm 20V$ $-20V \leq V_{CM} \leq 19.15V$ $-20V \leq V_{CM} \leq 19V$	93	102		90	102		dB
			87			87			dB
PSRR	Power Supply Rejection Ratio	$-0.2V \geq V^- \geq -39V$ $V^+ = 1.0V$ $V^+ = 1.1V$	90	96		87	96		dB
			84			84			dB
		$V^- = -0.2V$ $1.0V \leq V^+ \leq 39.8V$ $1.1V \leq V^+ \leq 39.8V$	96	106		93	106		dB
			90					dB	
R_{in}	Input Resistance	(Note 6)	250	500		150	400		k Ω
			150			115			k Ω
I_S	Supply Current			270	400		300	500	μA
					500			570	μA
ΔI_S	Supply Current Change	$1.2V \leq V_S \leq 40V$ $1.3V \leq V_S \leq 40V$		15	75		15	75	μA
					75			75	μA

REFERENCE AMPLIFIER ELECTRICAL CHARACTERISTICS (Note 3)

SYMBOL	PARAMETER	CONDITIONS	LM10/LM10B			LM10C			UNITS
			MIN	TYP	MAX	MIN	TYP	MAX	
V_{REF}	Feedback Sense Voltage	Voltage at Pin 1 with Pin 1 Connected to Pin 8	195	200	205	190	200	210	mV
			194	200	206	189	200	211	mV
$\frac{\Delta V_{REF}}{\Delta T_{EMO}}$	Reference Drift			0.002			0.003	% / $^{\circ}C$	
	Feedback Current	Current into Pin 8		20	50		22	75	nA
					65			90	nA
	Line Regulation	$0 \leq I_{REF} \leq 1mA$, $V_{REF} = 200mV$ $1.2V \leq V_S \leq 40V$ $1.3V \leq V_S \leq 40V$		0.001	0.003		0.001	0.008	% / V
				0.001	0.006		0.001	0.01	% / V
	Load Regulation	$0 \leq I_{REF} \leq 1mA$ $V^+ - V_{REF} \geq 1.0V$ $V^+ - V_{REF} \geq 1.1V$		0.01	0.1		0.01	0.15	%
				0.01	0.15		0.01	0.20	%
	Reference Amplifier Gain	$0.2V \leq V_{REF} \leq 35V$	50	75		25	70		V/mV
			23			15			V/mV

OP AMP ELECTRICAL CHARACTERISTICS (Note 3)

SYMBOL	PARAMETER	CONDITIONS	LM10BL			LM10CL			UNITS
			MIN	TYP	MAX	MIN	TYP	MAX	
V_{OS}	Input Offset Voltage		●	0.3	2.0		0.5	4.0	mV mV
$\frac{\Delta V_{OS}}{\Delta Temp}$	Average Offset Voltage Drift		●	2.0		5.0			$\mu V/^\circ C$
I_{OS}	Input Offset Current	(Note 4)	●	0.1	0.7		0.2	2.0	nA nA
$\frac{\Delta I_{OS}}{\Delta Temp}$	Offset Current Drift		●	2.0	1.5		5.0		$\mu A/^\circ C$
I_B	Input Bias Current		●	10	20		12	30	nA nA
$\frac{\Delta I_B}{\Delta Temp}$	Bias Current Drift		●	60	30		90		$\mu A/^\circ C$
A_{VOL}	Large Signal Voltage Gain	$V_S = \pm 3.25V, I_{OUT} = 0, V_{OUT} = \pm 3.2V$	●	60	300		40	300	V/mV V/mV
		$V_S = \pm 3.25V, V_{OUT} = \pm 2.75V$ $I_{OUT} = \pm 10mA$	●	10	25		5	25	V/mV V/mV
		$I_{OUT} = \pm 2mA, V_{CM} = -0.4V$ $V_S = \pm 0.6V, V_{OUT} = \pm 0.4V$ $V_S = \pm 0.65V, V_{OUT} = \pm 0.3V$	●	1.5	3.0		1.0	3.0	V/mV V/mV
	Shunt Gain (Note 5)	$0.1mA \leq I_{OUT} \leq 10mA, R_L = 500\Omega$ $1.5V \leq V^+ \leq 6.5V$	●	8	30		6	30	V/mV V/mV
			●	4			4		
CMRR	Common-Mode Rejection Ratio	$V_S = \pm 3.25V$ $-3.25V \leq V_{CM} \leq 2.4V$ $-3.25V \leq V_{CM} \leq 2.25V$	●	89	102		80	102	dB dB
PSRR	Power Supply Rejection Ratio	$-0.2V \geq V^- \geq -5.4V$ $V^+ = 1.0V$ $V^+ = 1.2V$	●	86	96		80	96	dB dB
PSRR		$V^- = -0.2V$ $1.0V \leq V^+ \leq 6.3V$ $1.1V \leq V^+ \leq 6.3V$	●	94	106		80	106	dB dB
			●	88			74		
R_{IN}	Input Resistance	(Note 6)	●	250	500		150	400	k Ω k Ω
			●	150			115		
I_S	Supply Current		●	260	400		280	500	μA μA
			●		500			570	

REFERENCE AMPLIFIER ELECTRICAL CHARACTERISTICS (Note 3)

SYMBOL	PARAMETER	CONDITIONS	LM10BL			LM10CL			UNITS
			MIN	TYP	MAX	MIN	TYP	MAX	
V_{REF}	Feedback Sense Voltage	Voltage at Pin 1 with Pin 1 Connected to Pin 8	195 194	200 200	205 206	190 189	200 200	210 211	mV mV
$\frac{\Delta V_{REF}}{\Delta Temp}$	Reference Drift		0.002			0.003			% / °C
	Feedback Current	Current into Pin 8	20	50 65		22	75 90		nA nA
	Line Regulation	$0 \leq I_{REF} \leq 0.5mA$, $V_{REF} = 200mV$ $1.2V \leq V_S \leq 6.5V$ $1.3V \leq V_S \leq 6.5V$	0.001 0.001	0.01 0.02		0.001 0.001	0.02 0.03		% / V % / V
	Load Regulation	$0 \leq I_{REF} \leq 0.5mA$ $V^+ - V_{REF} \geq 1.0V$ $V^+ - V_{REF} \geq 1.1V$	0.01 0.01	0.1 0.15		0.01 0.01	0.15 0.20		% %
	Reference Amplifier Gain	$0.2V \leq V_{REF} \leq 5.5V$	30 20	70		20 15	70		V/mV V/mV

The ● denotes the specifications which apply over full operating temperature range.

Note 1: The input voltage can exceed the supply voltages as long as the voltage from the input to any other terminal does not exceed the maximum differential voltage, and the maximum junction temperature is not exceeded due to the excess power dissipation that occurs when the input voltage is less than the negative supply voltage.

Note 2: The maximum operating junction temperatures are: 150°C for the LM10; 100°C for the LM10B and LM10BL; and 85°C for the LM10C and LM10CL. Package derating factors will be found on the back page of this data sheet.

Note 3: These specifications apply for the following conditions unless otherwise noted:

at 25°C

$$(a) V^- \leq V_{CM} \leq V^+ - 0.85V$$

$$(b) 1.2V \leq V_S \leq V_{MAX}$$

over temperature

$$V^- \leq V_{CM} \leq V^+ - 1.0V$$

$$1.3V \leq V_S \leq V_{MAX}$$

$V_{REF} = 0.2V$ and $0 \leq I_{REF} \leq 1.0mA$ where $V_{MAX} = 40V$ for the LM10, LM10B and LM10C and $V_{MAX} = 6.5V$ for the LM10BL and LM10CL. The specifications do not include errors due to thermal gradients ($\tau_1 \approx 20ms$), die heating ($\tau_2 \approx 0.2$ sec) or package heating.

Note 4: For $T_J > 90^\circ C$, I_{OS} may exceed 1.5nA when $V_{CM} = V^-$. When the common-mode input voltage is within 100mV of the negative supply and $T_J = 125^\circ C$, the offset current will be less than 5nA.

Note 5: Shunt gain defines the operation in floating applications when the output is connected to the V^+ terminal and input common-mode is referred to V^- (see typical applications). The effects of larger output voltage swing with higher load resistance can be accounted for by adding the positive supply rejection error.

Note 6: Guaranteed by design.

TYPICAL PERFORMANCE CHARACTERISTICS (Op Amp)

Input Current

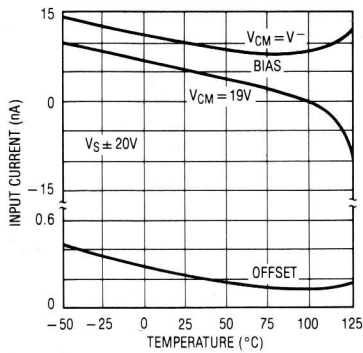

Common-Mode Limits

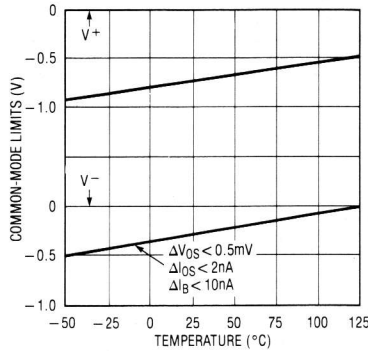

Offset Voltage Drift

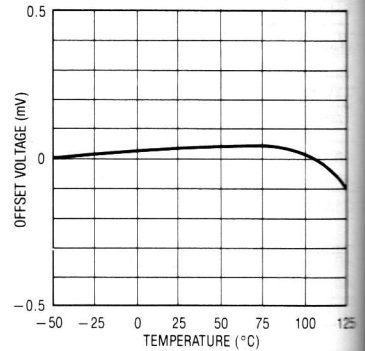

Input Noise Voltage

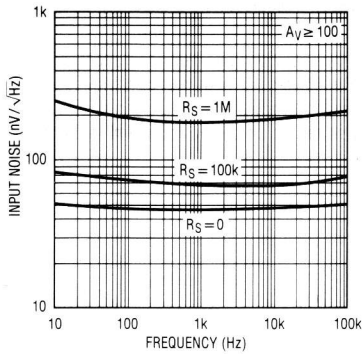

DC Voltage Gain

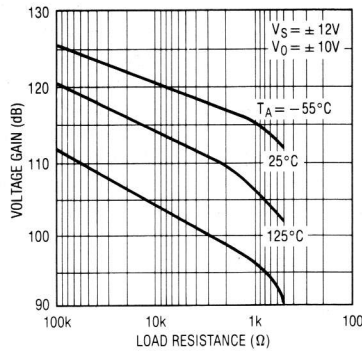

Transconductance

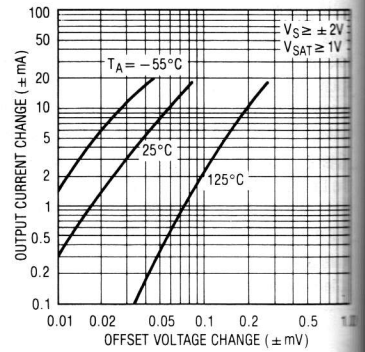

Output Saturation Characteristics

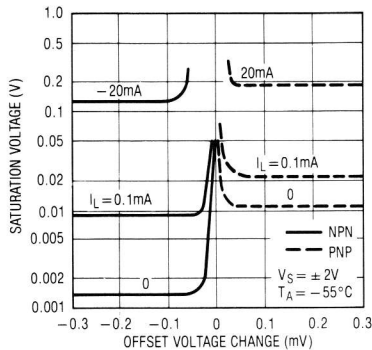

Output Saturation Characteristics

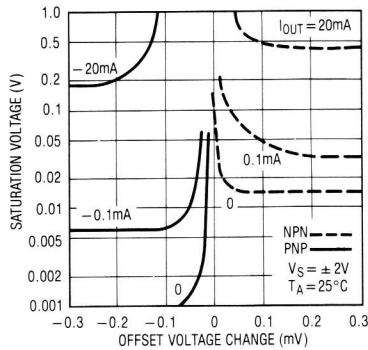

Output Saturation Characteristics

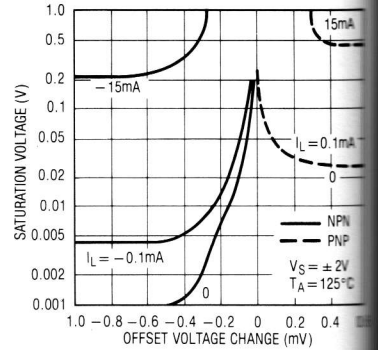

TYPICAL PERFORMANCE CHARACTERISTICS (Op Amp)

Minimum Supply Voltage

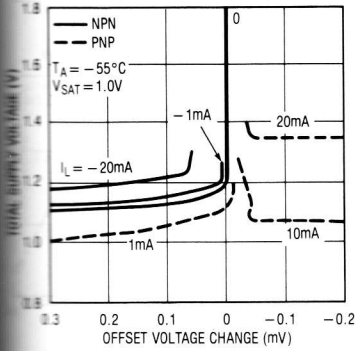

Minimum Supply Voltage

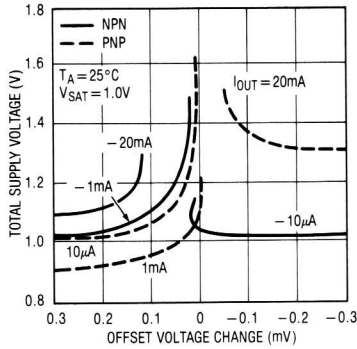

Minimum Supply Voltage

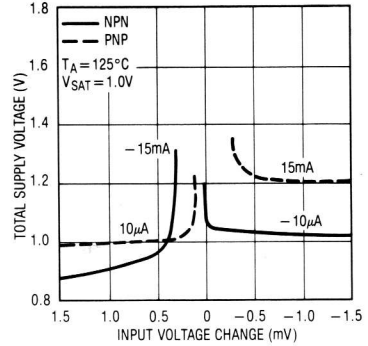

Frequency Response

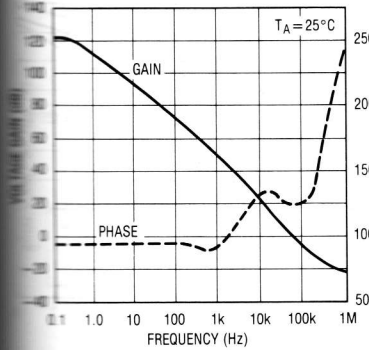

Output Impedance

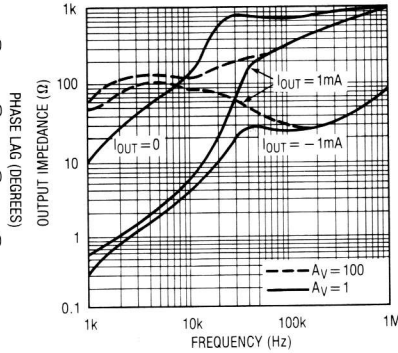

Typical Stability Range

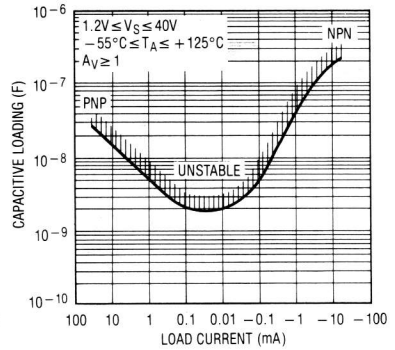

Large Signal Response

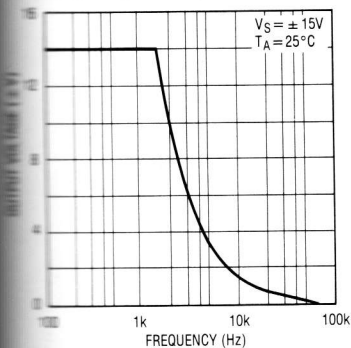

Comparator Response Time for Various Input Overdrives

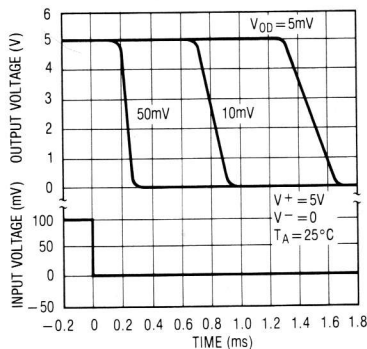

Comparator Response Time for Various Input Overdrives

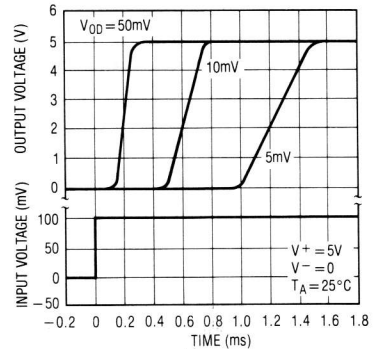

TYPICAL PERFORMANCE CHARACTERISTICS

Follower Pulse Response

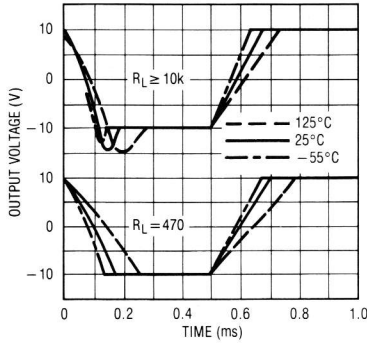

Noise Rejection

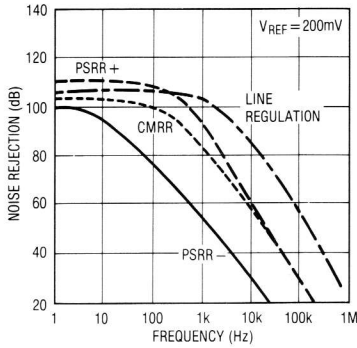

Rejection Slew Limiting

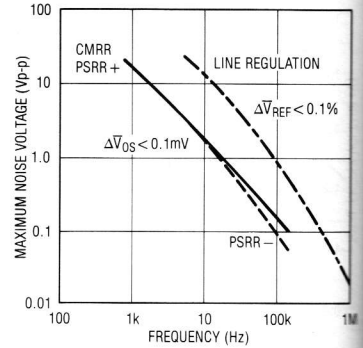

Shunt Gain

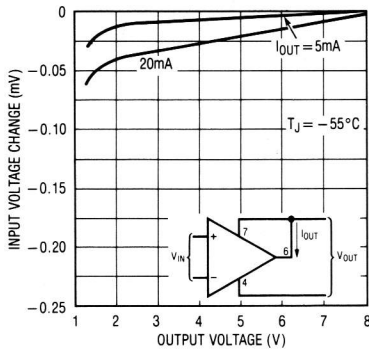

Shunt Gain

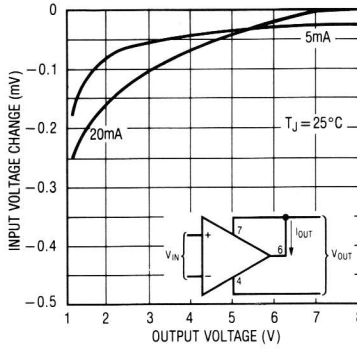

Shunt Gain

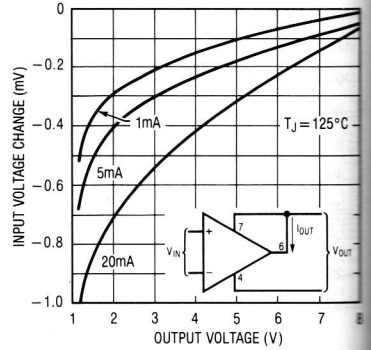

Thermal Gradient Feedback

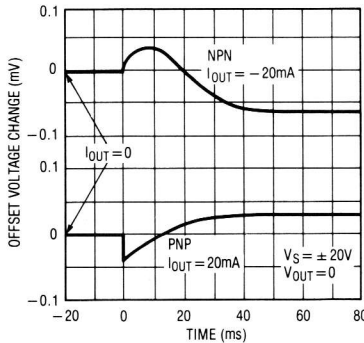

Change in Reference Op Amp Loading

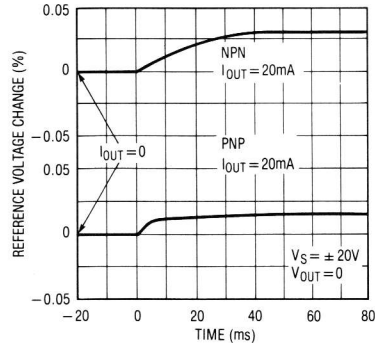

TYPICAL PERFORMANCE CHARACTERISTICS (Reference)

Supply Current

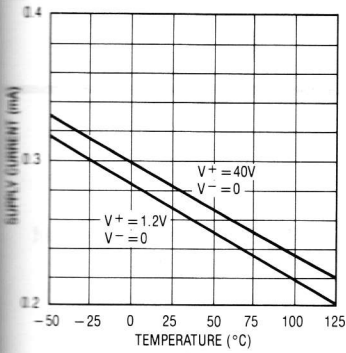

Load Regulation

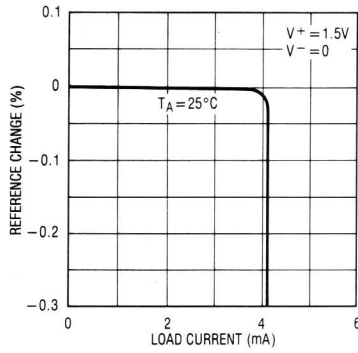

Reference Noise Voltage

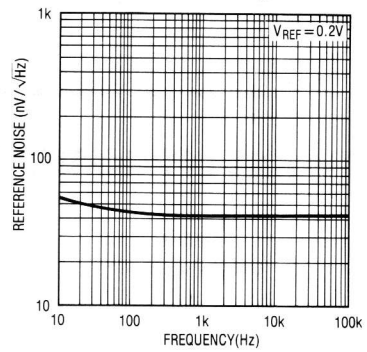

Minimum Supply Voltage

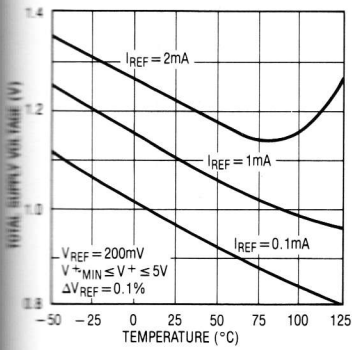

Output Saturation

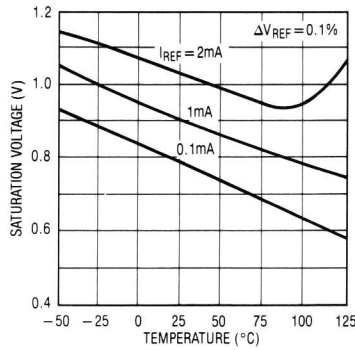

Typical Stability Range

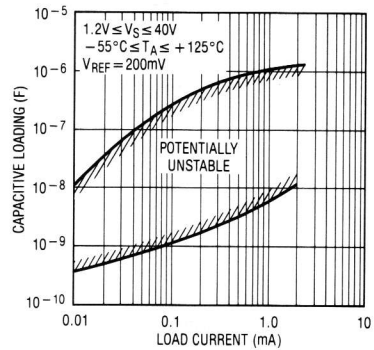

BLOCK DIAGRAM

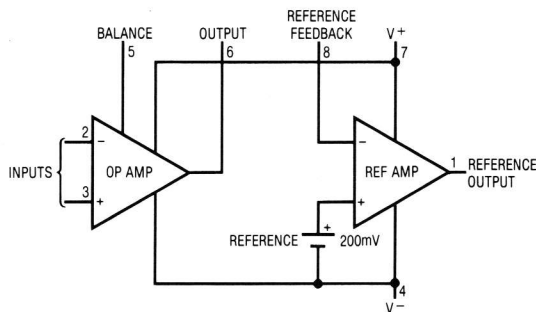

TYPICAL APPLICATIONS

Microphone Amplifier
 $A_V \approx 1k$

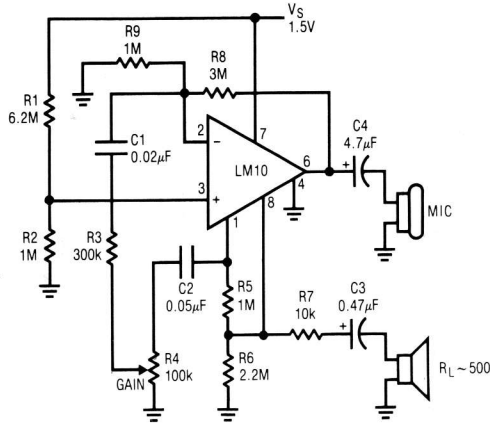

Isolated Voltage Sensor
 for Switching Regulators

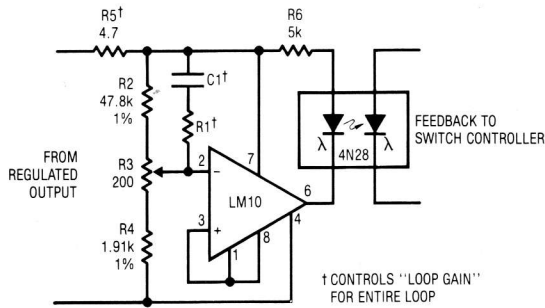

OP AMP SCHEMATIC DIAGRAM

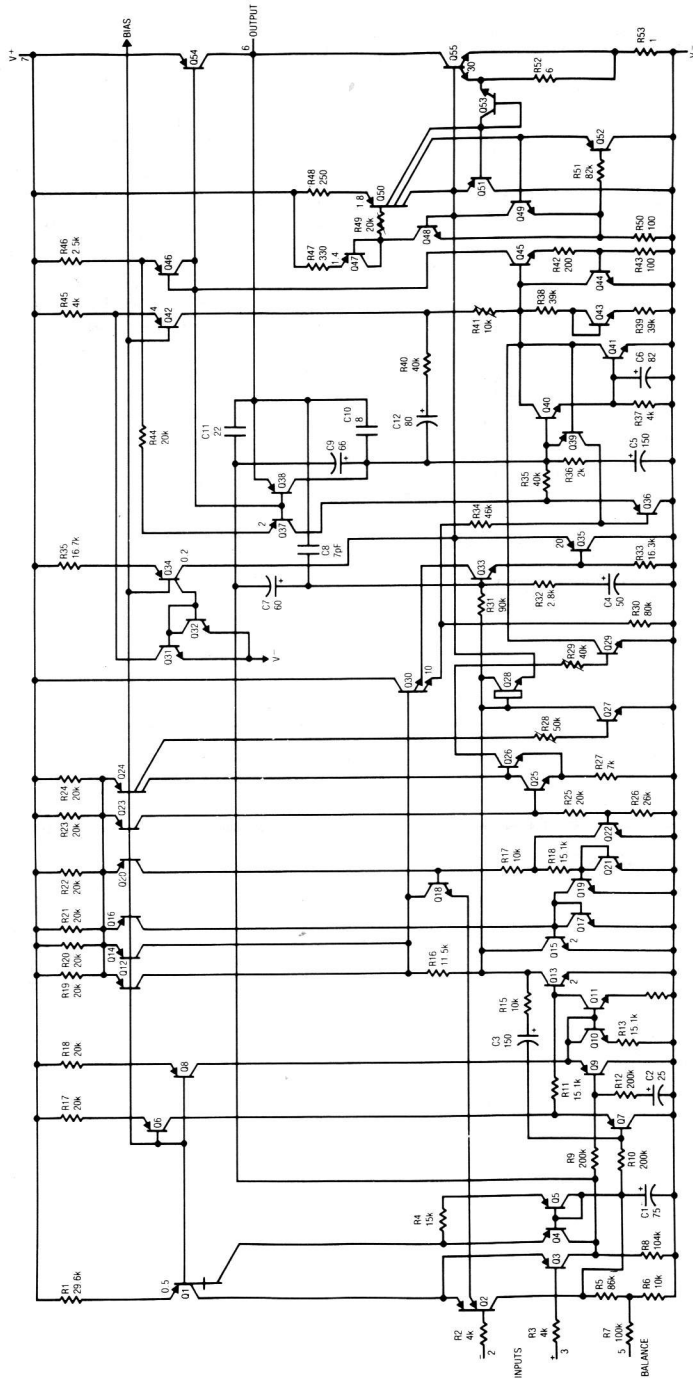

REFERENCE AND INTERNAL REGULATOR SCHEMATIC DIAGRAM

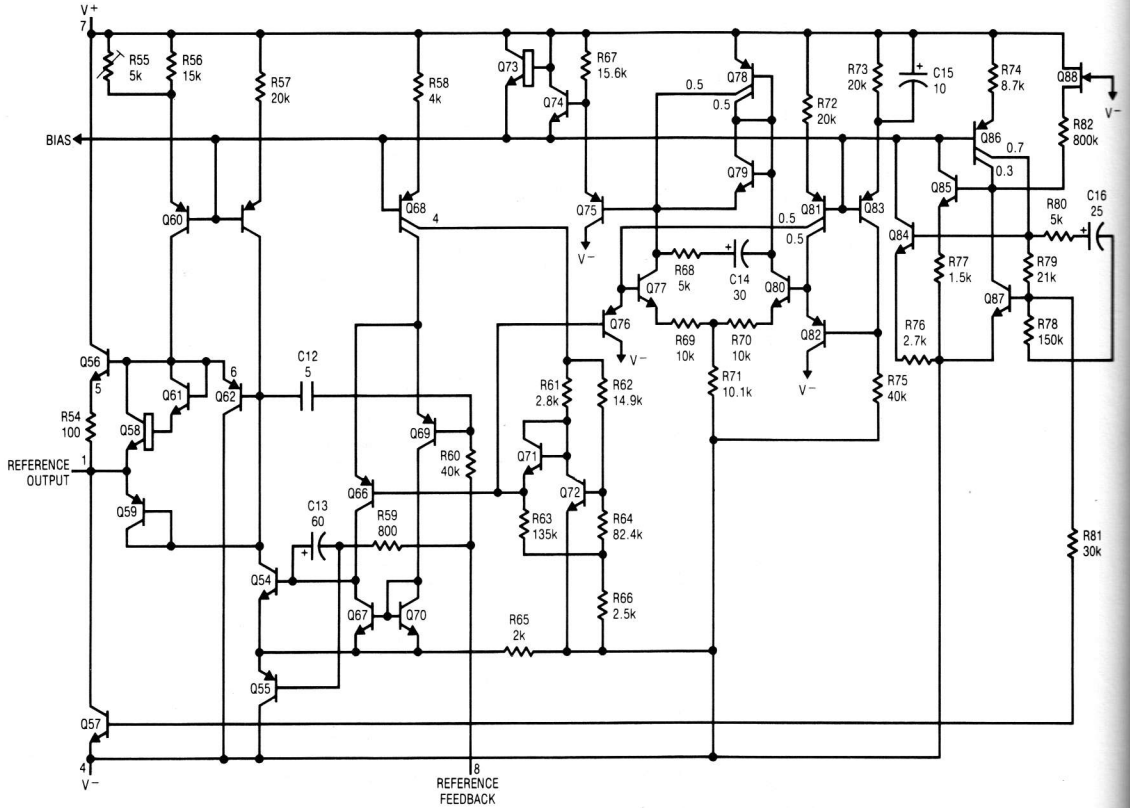

PACKAGE DESCRIPTION

H Package
Metal Can

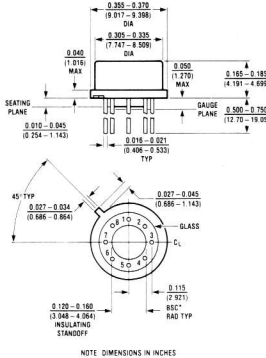

J8 Package
8 Lead Hermetic Dip

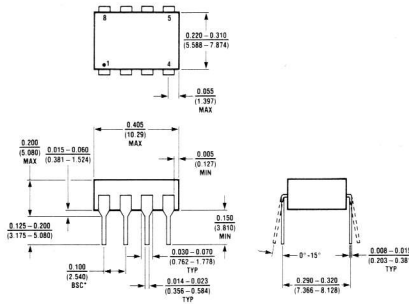

N8 Package
8 Lead Plastic

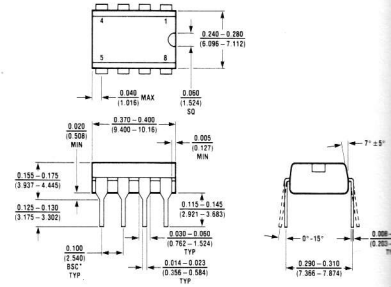

T _{jmax}	θ _{ja}	θ _{jc}
150°C	150°C/W	45°C/W

T _{jmax}	θ _{ja}
150°C	100°C/W

T _{jmax}	θ _{ja}
100°C	130°C/W