

LM144/LM344 high voltage, high slew rate operational amplifier

general description

The LM144 is a general purpose high voltage, uncompensated operational amplifier featuring operation to $\pm 36V$, complete input overvoltage protection up to the supply voltages and input currents comparable to those of other super- β op amps. Increased slew rate, together with high common-mode and supply rejection, insure excellent performance at high supply voltages. Operating characteristics, in particular supply current, slew rate and gain, are virtually independent of supply voltage and temperature. Furthermore, due to thermal symmetry on the die, gain is unaffected by output loading at high supply voltages.

With the unique advantages of low input current, high gain, and high slew rate, the LM144 can increase accuracy and useful frequency range in many existing applications. For example, the LM144 is a plug-in replacement for the LM101A, as well as other general purpose op amps.

The LM144 can be compensated with a single capacitor, thus giving the user the ability to optimize ac parameters to suit the application. For example, in applications such as audio power amplifiers, the LM144 with a gain of 10 can provide a $\pm 30V$ output swing, a slew rate of approximately $30V/\mu s$, and a 120 kHz full power

bandwidth. In applications where capacitive loads or cables must be driven, the LM144 can be overcompensated for increased stability.

The LM344 is similar to the LM144 for applications in less severe supply voltage and temperature environments.

features

- External compensation provides large power bandwidth ($A_V \geq 10$) 120 kHz
- Wide operating voltage range $\pm 4.0V$ to $\pm 36V$
- Large output voltage swing $\pm 30V$
- Wide input common-mode range
- Input overvoltage protection
- Electrical characteristics independent of supply voltage and temperature

unique characteristics

- Low input bias current 8.0 nA
- Low input offset current 1.0 nA
- High slew rate ($A_V \geq 10$) $30V/\mu s$
- High voltage gain 100k min
- Offset voltage null capability

typical application

Large Power Bandwidth, Current Boosted Audio Line Driver

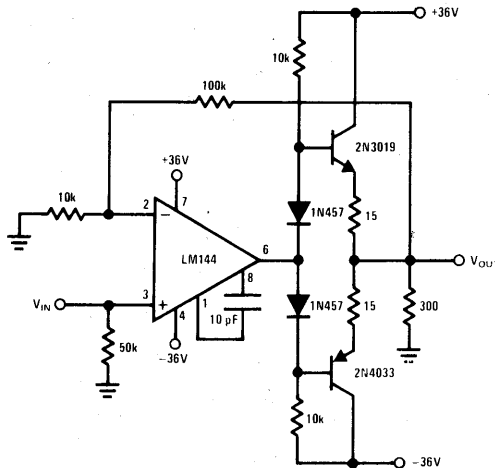

LM144

absolute maximum ratings (These ratings are not concurrent)

	LM144	LM344
Supply Voltage	±40V	±34V
Power Dissipation (Note 1)	680 mW	680 mW
Differential Input Voltage (Note 2)	80V	68V
Input Voltage (Note 2)	±40V	±34V
Operating Temperature Range	-55°C to +125°C	0°C to +70°C
Storage Temperature Range	-65°C to +150°C	-65°C to +150°C
Output Short Circuit Duration	5 seconds	5 seconds
Lead Temperature (Soldering, 10 seconds)	300°C	300°C

electrical characteristics (Note 3)

PARAMETER	CONDITIONS	LM144			LM344			UNITS
		MIN	TYP	MAX	MIN	TYP	MAX	
Input Offset Voltage	$T_A = 25^\circ\text{C}$		2.0	5.0		2.0	8.0	mV
Input Offset Current	$T_A = 25^\circ\text{C}$		1.0	3.0		1.0	10	nA
Input Bias Current	$T_A = 25^\circ\text{C}$		8.0	20		8.0	40	nA
Supply Voltage Rejection Ratio	$T_A = 25^\circ\text{C}$		10	100		10	200	$\mu\text{V/V}$
Output Voltage Swing	$T_A = 25^\circ\text{C}$, $R_L \geq 5\text{ k}\Omega$	22	25		20	25		V
Large Signal Voltage Gain	$T_A = 25^\circ\text{C}$, $V_{\text{OUT}} = \pm 10\text{V}$, $R_L \geq 100\text{ k}\Omega$	100k	180k		70k	180k		V/V
Common-Mode Rejection Ratio	$T_A = 25^\circ\text{C}$	80	90		70	90		dB
Input Voltage Range	$T_A = 25^\circ\text{C}$	24	26		22	26		V
Supply Current	$T_A = 25^\circ\text{C}$		2.0	4.0		2.0	5.0	mA
Short Circuit Current	$T_A = 25^\circ\text{C}$		20			20		mA
Slew Rate	$T_A = 25^\circ\text{C}$, $A_V = 1$		2.5			2.5		V/ μs
	$T_A = 25^\circ\text{C}$, $A_V = 10$, $C_1 = 3\text{ pF}$		30			30		V/ μs
Power Bandwidth	$T_A = 25^\circ\text{C}$, $V_{\text{OUT}} = 40 V_{\text{PP}}$, $R_L = 5\text{ k}\Omega$, $\text{THD} \leq 1\%$, $A_V = 1$		20k			20k		Hz
Unity Gain Frequency	$T_A = 25^\circ\text{C}$		1.0M			1.0M		Hz
Input Offset Voltage	$T_A = \text{Max}$			6.0			10	mV
	$T_A = \text{Min}$			6.0			10	mV
Input Offset Current	$T_A = \text{Max}$		0.8	4.5		0.8	14	nA
	$T_A = \text{Min}$		1.8	7.0		1.8	14	nA
Input Bias Current	$T_A = \text{Max}$		5.0	35		5.0	55	nA
	$T_A = \text{Min}$		16	35		16	55	nA
Large Signal Voltage Gain	$R_L \geq 100\text{ k}\Omega$, $T_A = \text{Max}$	50k	150k		50k	150k		V/V
	$R_L \geq 100\text{ k}\Omega$, $T_A = \text{Min}$	50k	220k		50k	220k		V/V
Output Voltage Swing	$R_L \geq 5.0\text{ k}\Omega$, $T_A = \text{Max}$	22	26		20	26		V
	$R_L \geq 5.0\text{ k}\Omega$, $T_A = \text{Min}$	22	25		20	25		V

Note 1: The maximum junction temperature of the LM144 is 150°C, while that of the LM344 is 100°C. For operating at elevated temperatures, devices in the TO-5 package must be derated based on a thermal resistance of 150°C/W, junction to ambient, or 45°C/W, junction to case. For the flat package, the derating is based on a thermal resistance of 185°C/W when mounted on a 1/16-inch-thick epoxy glass board with ten, 0.03-inch-wide, 2-ounce copper conductors. The thermal resistance of the dual-in-line package is 100°C/W, junction to ambient.

Note 2: For supply voltage less than ±40V for the LM144 and less than ±34V for the LM344, the absolute maximum input voltage is equal to the supply voltage.

Note 3: These specifications apply for $V_S = \pm 28\text{V}$. For the LM144, $T_A = \text{max} = 125^\circ\text{C}$ and $T_A = \text{min} = -55^\circ\text{C}$. For the LM344, $T_A = \text{max} = 70^\circ\text{C}$ and $T_A = \text{min} = 0^\circ\text{C}$.

schematic diagram

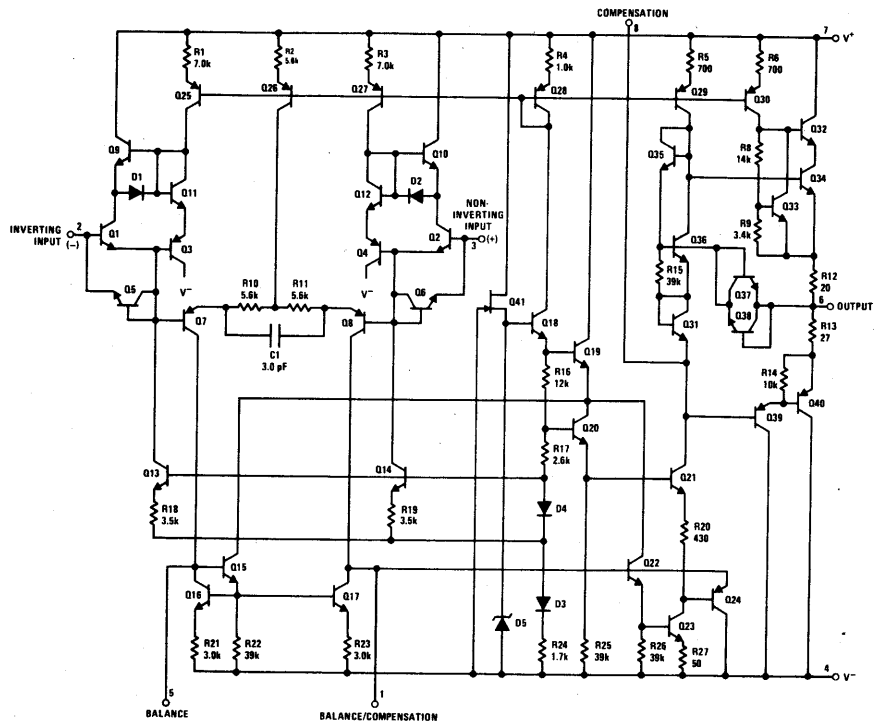

typical performance characteristics

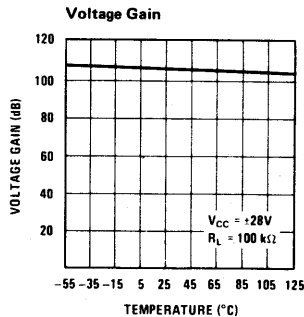
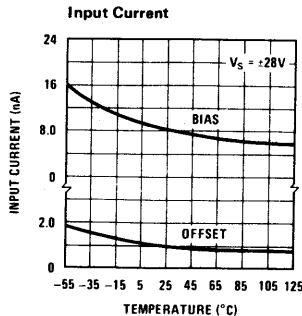
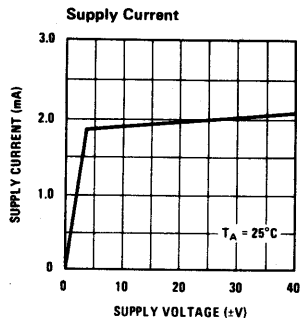
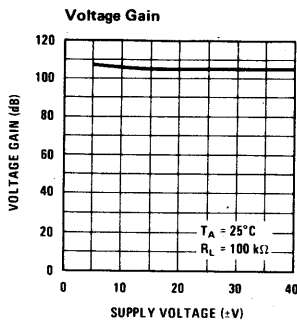
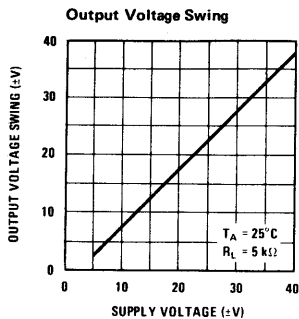
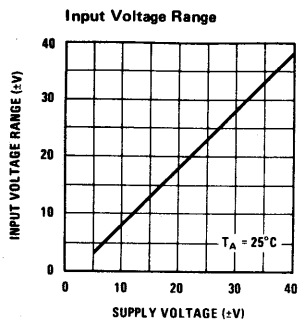

typical performance characteristics (con't)

Voltage Follower Slew Rate

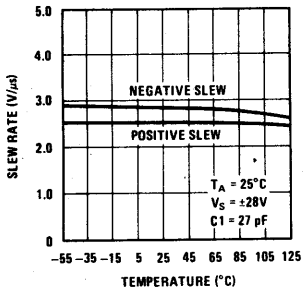

Supply Current

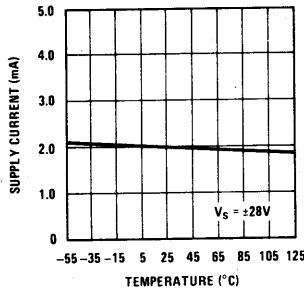

Short Circuit Current

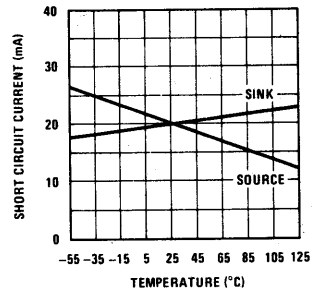

Unity Gain Bandwidth

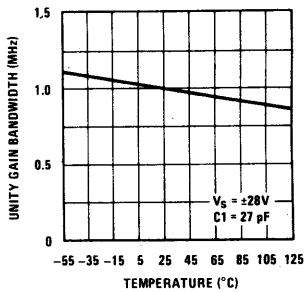

Input Noise Voltage

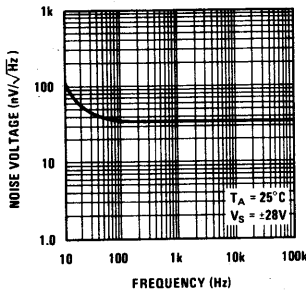

Input Noise Current

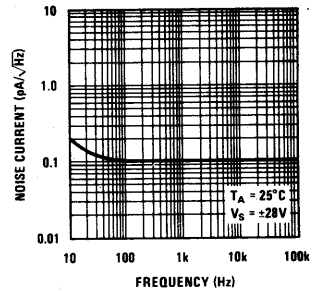

Common-Mode Rejection

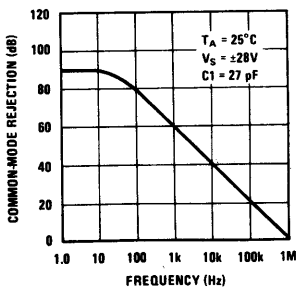

Power Supply Rejection

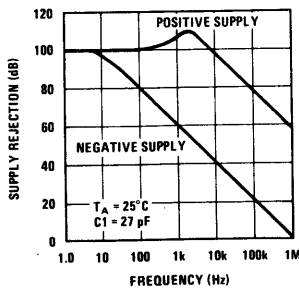

Large Signal Frequency Response

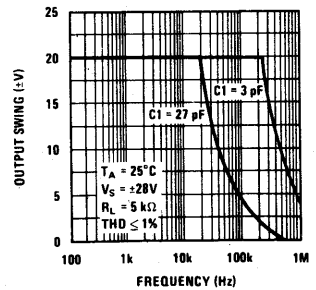

Open Loop Frequency Response

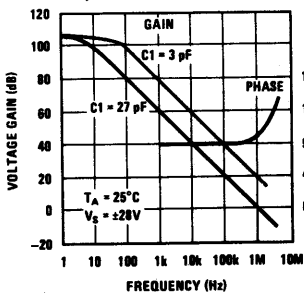

Voltage Follower Pulse Response

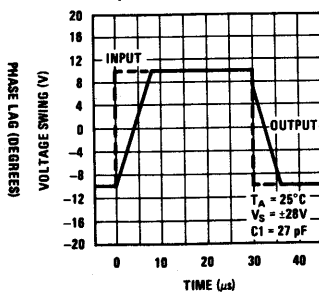

Inverter Pulse Response

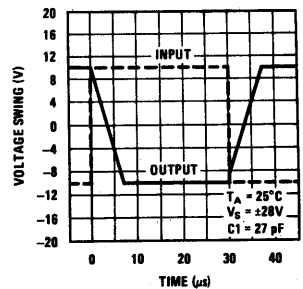

application hints (See Also AN-127)

The LM144 is designed for trouble-free operation at any supply voltage up to a maximum of $\pm 40V$. Input over-voltage protection, both common-mode and differential, is 100% tested and guaranteed at the maximum supply voltage. Furthermore, all possible high voltage destructive modes during supply voltage turn-on have been eliminated by design. As with most IC op amps, however, certain precautions should be observed to insure that the LM144 remains virtually blow-out proof.

Although output short circuits to ground or either supply can be sustained indefinitely for supply voltages, below $\pm 18V$, these short circuits should be of limited duration when operating at higher supply voltages. Units can be destroyed by any combination of high ambient temperature, high supply voltages, and high power dissipation which results in excessive die temperature. This is also true when driving low impedance or reactive loads or loads that can revert to low impedance; for example, the LM144 can drive most general purpose op amps outside of their maximum input voltage range, causing heavy current to flow and possibly destroying both devices.

Precautions should be taken to insure that the power supplies never become reversed in polarity—even under transient conditions. With reverse voltage, the IC will conduct excessive current, fusing the internal aluminum interconnects. Voltage reversal between the power supplies will almost always result in a destroyed unit.

In high voltage applications which are sensitive to very low input currents, special precautions should be exer-

cised. For example, with high source resistances, care should be taken to prevent the magnitude of the PC board leakage currents, although quite small, from approaching those of the op amp input currents. These leakage currents become larger at $125^{\circ}C$ and are made worse by high supply voltages. To prevent this, PC boards should be properly cleaned and coated to prevent contamination and to provide protection from condensed water vapor when operation below $0^{\circ}C$. A guard ring is also recommended to significantly reduce leakage currents from the op amp input pins to the adjacent high voltage pins in the standard op amp pin connection as shown in *Figure 1*. *Figures 2, 3 and 4* show how the guard ring is connected for the three most common op amp configurations.

The minimum values given for the frequency compensation capacitor are stable only for source resistances less than $10\text{ k}\Omega$, stray capacitances on the summing junction less than 5 pF and capacitive loads smaller than 100 pF . If any of these conditions are not met, it becomes necessary to overcompensate the amplifier with a larger compensation capacitor. Alternately, lead capacitors can be used in the feedback network to negate the effect of stray capacitance and large feedback resistors or an RC network can be added to isolate capacitive loads. See *Figures 5, 6 and 7*.

Finally, caution should be exercised in high voltage applications as electrical shock hazards are present. Since the negative supply is connected to the case, users may inadvertently contact voltages equal to those across the power supplies.

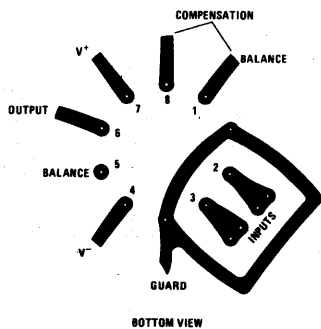

FIGURE 1. Printed Circuit Layout for Input Guarding with TO-5 Package

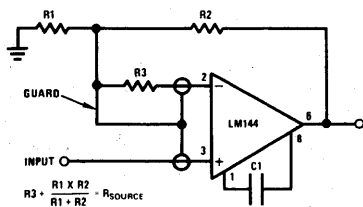

FIGURE 3. Guarded Non-Inverting Amplifier

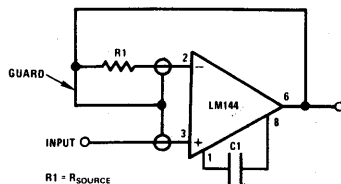

FIGURE 2. Guarded Voltage Follower

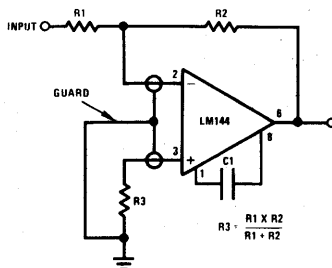
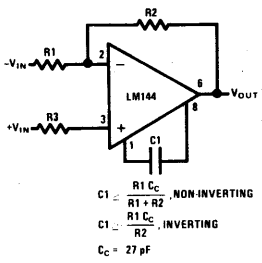

FIGURE 4. Guarded Inverting Amplifier

application hints (con't)



$$C1 = \frac{R1 \cdot Cc}{R1 + R2} \text{ , NON-INVERTING}$$

$$C1 = \frac{R1 \cdot Cc}{R2} \text{ , INVERTING}$$

$$Cc = 27 \text{ pF}$$

FIGURE 5. Single Pole Compensation

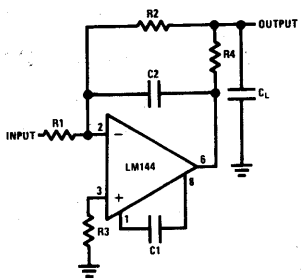

FIGURE 6. Isolating Large Capacitive Loads

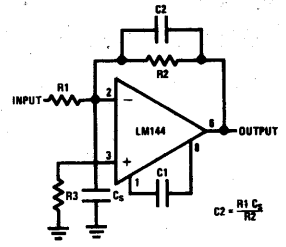
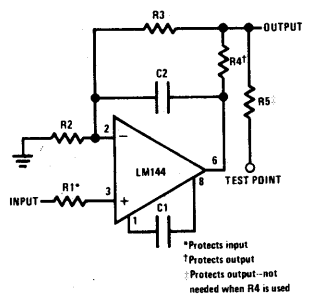

FIGURE 7. Compensating For Stray Input Capacitances or Large Feedback Resistor



*Protects input
*Protects output
*Protects output—not needed when R4 is used

FIGURE 8. Protecting Against Gross Fault Conditions

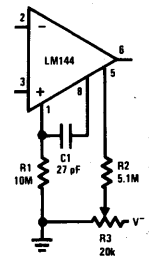
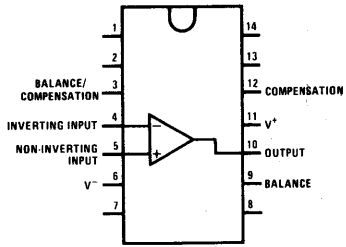

FIGURE 9. Balancing Circuit

connection diagrams

Dual-In-Line Package



Note: Pin 6 connected to bottom of package.
TOP VIEW

Order Number LM144D or LM344D
See NS Package D14E

Fiat Package

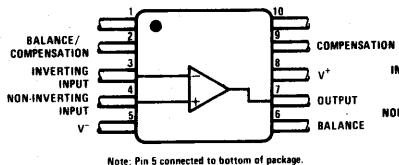

Note: Pin 5 connected to bottom of package.
TOP VIEW

Order Number LM144F
See NS Package F10A

Metal Can Package

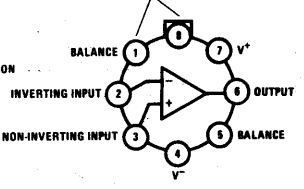

NOTE: Pin 4 connected to case.
TOP VIEW

Order Number LM144H or LM344H
See NS Package H08C