

## FEATURES

- **Guaranteed Low Offset Voltage**
  - LT1001AM 15 $\mu$ V max
  - LT1001C 60 $\mu$ V max
- **Guaranteed Low Drift**
  - LT1001AM 0.6 $\mu$ V/ $^{\circ}$ C max
  - LT1001C 1.0 $\mu$ V/ $^{\circ}$ C max
- **Guaranteed Low Bias Current**
  - LT1001AM 2nA max
  - LT1001C 4nA max
- **Guaranteed CMRR**
  - LT1001AM 114dB min
  - LT1001C 110dB min
- **Guaranteed PSRR**
  - LT1001AM 110dB min
  - LT1001C 106dB min
- **Low Power Dissipation**
  - LT1001AM 75mW max
  - LT1001C 80mW max
- **Low Noise 0.3 $\mu$ V<sub>p-p</sub>**

## DESCRIPTION

The LT1001 significantly advances the state-of-the-art of precision operational amplifiers. In the design, processing, and testing of the device, particular attention has been paid to the optimization of the entire distribution of several key parameters. Consequently, the specifications of the lowest cost, commercial temperature device, the LT1001C, have been dramatically improved when compared to equivalent grades of competing precision amplifiers.

Essentially, the input offset voltage of all units is less than 50 $\mu$ V (see distribution plot below). This allows the LT1001AM/883 to be specified at 15 $\mu$ V. Input bias and offset currents, common-mode and power supply rejection of the LT1001C offer guaranteed performance which were previously attainable only with expensive, selected grades of other devices. Power dissipation is nearly halved compared to the most popular precision op amps, without adversely affecting noise or speed performance. A beneficial by-product of lower dissipation is decreased warm-up drift. Output drive capability of the LT1001 is also enhanced with voltage gain guaranteed at 10 mA of load current. For similar performance in a dual precision op amp, with guaranteed matching specifications, see the LT1002. Shown below is a platinum resistance thermometer application.

## APPLICATIONS

- Thermocouple amplifiers
- Strain gauge amplifiers
- Low level signal processing
- High accuracy data acquisition

**Linearized Platinum Resistance Thermometer with  $\pm 0.025^{\circ}$ C Accuracy Over 0 to 100 $^{\circ}$ C**

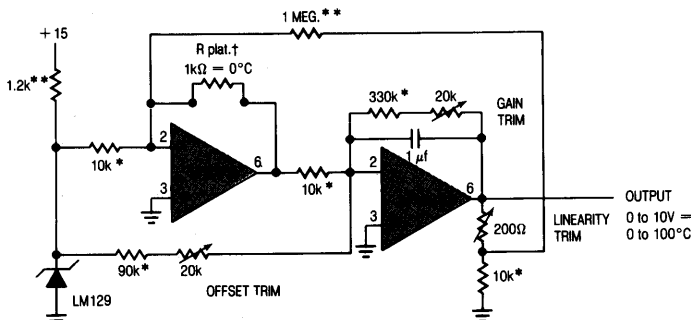

\* ULTRONIX 105A WIREWOUND  
 \*\* 1% FILM  
 † PLATINUM RTD  
 118MF (ROSEMOUNT, INC.)

‡ Trim sequence: trim offset (0 $^{\circ}$ C = 1000.00), trim linearity (35 $^{\circ}$ C = 1138.70), trim gain (100 $^{\circ}$ C = 1392.60). Repeat until all three points are fixed with  $\pm 0.025^{\circ}$ C.

**Typical Distribution of Offset Voltage**  
 $V_S = \pm 15V, T_A = 25^{\circ}C$

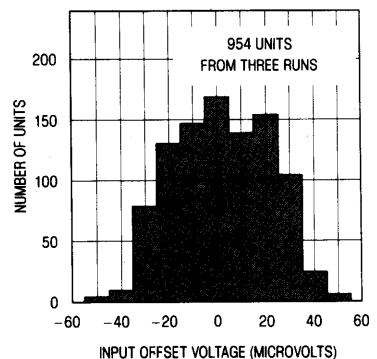

**ABSOLUTE MAXIMUM RATINGS**

Supply Voltage .....  $\pm 22V$   
 Differential Input Voltage .....  $\pm 30V$   
 Input Voltage .....  $\pm 22V$   
 Output Short Circuit Duration ..... Indefinite  
 Operating Temperature Range  
 LT1001AM/LT1001M .....  $-55^{\circ}C$  to  $150^{\circ}C$   
 LT1001AC/LT1001C .....  $0^{\circ}C$  to  $125^{\circ}C$   
 Storage: All Devices .....  $-65^{\circ}C$  to  $150^{\circ}C$   
 Lead Temperature (Soldering, 10 sec.) .....  $300^{\circ}C$

**PACKAGE/ORDER INFORMATION**

<p>TOP VIEW OFFSET ADJUST</p>	<p>ORDER PART NUMBER</p> <p>LT1001AMH/883              LT1001MH              LT1001ACH              LT1001CH</p>
<p>TOP VIEW</p> <p>J8 PACKAGE 8 PIN HERMETIC DIP</p> <p>N8 PACKAGE 8 PIN PLASTIC DIP</p>	<p>LT1001AMJ8/883              LT1001MJ8              LT1001ACJ8              LT1001CJ8</p> <p>LT1001ACN8              LT1001CN8</p>

**ELECTRICAL CHARACTERISTICS**  $V_s = \pm 15V, T_A = 25^{\circ}C$ , unless otherwise noted

SYMBOL	PARAMETER	CONDITIONS	LT1001AM/883 LT1001AC			LT1001M/LT1001C			UNITS
			MIN	TYP	MAX	MIN	TYP	MAX	
$V_{OS}$	Input Offset Voltage	Note 1 LT1001AM/883 LT1001AC		7 15		18	60		$\mu V$
$\frac{\Delta V_{OS}}{\Delta \text{Time}}$	Long Term Input Offset Voltage Stability	Notes 2 and 3		0.2 1.0		0.3	1.5		$\mu V/\text{month}$
$I_{OS}$	Input Offset Current			0.3 2.0		0.4	3.8		nA
$I_b$	Input Bias Current			$\pm 0.5$ $\pm 2.0$		$\pm 0.7$ $\pm 4.0$			nA
$e_n$	Input Noise Voltage	0.1Hz to 10Hz (Note 2)		0.3 0.6		0.3	0.6		$\mu V_{P-P}$
$e_n$	Input Noise Voltage Density	$f_o = 10\text{Hz}$ (Note 5) $f_o = 1000\text{Hz}$ (Note 2)		10.3 9.6 18.0 11.0		10.5 9.8 18.0 11.0			$nV\sqrt{\text{Hz}}$
$A_{VOL}$	Large Signal Voltage Gain	$R_L \geq 2k\Omega, V_o = \pm 12V$ $R_L \geq 1k\Omega, V_o = \pm 10V$	450 300	800 500		400 250	800 500		V/mV
CMRR	Common Mode Rejection Ratio	$V_{CM} = \pm 13V$	114	126		110	126		dB
PSRR	Power Supply Rejection Ratio	$V_s = \pm 3V$ to $\pm 18V$	110	123		106	123		dB
$R_{in}$	Input Resistance Differential Mode	(Note 4)	30	100		15	80		M $\Omega$
	Input Voltage Range		$\pm 13$	$\pm 14$		$\pm 13$	$\pm 14$		V
$V_{OUT}$	Maximum Output Voltage Swing	$R_L \geq 2k\Omega$ $R_L \geq 1k\Omega$	$\pm 13$ $\pm 12$	$\pm 14$ $\pm 13.5$		$\pm 13$ $\pm 12$	$\pm 14$ $\pm 13.5$		V
$S_R$	Slew Rate	$R_L \geq 2k\Omega$ (Note 4)	0.1	0.25		0.1	0.25		V/ $\mu s$
GBW	Gain-Bandwidth Product	(Note 4)	0.4	0.8		0.4	0.8		MHz
$P_d$	Power Dissipation	No load No load, $V_s = \pm 3V$	46 4	75 6		48 4	80 8		mW

See Notes on page 3.

**ELECTRICAL CHARACTERISTICS**  $V_S = \pm 15V, -55^{\circ}C \leq T_A \leq 125^{\circ}C$ , unless otherwise noted

SYMBOL	PARAMETER	CONDITIONS	LT1001AM/883			LT1001M			UNITS
			MIN	TYP	MAX	MIN	TYP	MAX	
$V_{OS}$	Input Offset Voltage		●	30	60		45	160	$\mu V$
$\frac{\Delta V_{OS}}{\Delta Temp}$	Average Offset Voltage Drift		●	0.2	0.6		0.3	1.0	$\mu V/^{\circ}C$
$I_{OS}$	Input Offset Current		●	0.8	4.0		1.2	7.6	nA
$I_B$	Input Bias Current		●	$\pm 1.0$	$\pm 4.0$		$\pm 1.5$	$\pm 8.0$	nA
$A_{VOL}$	Large Signal Voltage Gain	$R_L \geq 2k\Omega, V_O = \pm 10V$	●	300	700		200	700	V/mV
CMRR	Common Mode Rejection Ratio	$V_{CM} = \pm 13V$	●	110	122		106	120	dB
PSRR	Power Supply Rejection Ratio	$V_S = \pm 3$ to $\pm 18V$	●	104	117		100	117	dB
	Input Voltage Range		●	$\pm 13$	$\pm 14$		$\pm 13$	$\pm 14$	V
$V_{OUT}$	Output Voltage Swing	$R_L \geq 2k\Omega$	●	$\pm 12.5$	$\pm 13.5$		$\pm 12.0$	$\pm 13.5$	V
$P_s$	Power Dissipation	No load	●	55	90		60	100	mW

$V_S = \pm 15V, 0^{\circ}C \leq T_A \leq 70^{\circ}C$ , unless otherwise noted

SYMBOL	PARAMETER	CONDITIONS	LT1001AC			LT1001C			UNITS
			MIN	TYP	MAX	MIN	TYP	MAX	
$V_{OS}$	Input Offset Voltage		●	20	60		30	110	$\mu V$
$\frac{\Delta V_{OS}}{\Delta Temp}$	Average Offset Voltage Drift		●	0.2	0.6		0.3	1.0	$\mu V/^{\circ}C$
$I_{OS}$	Input Offset Current		●	0.5	3.5		0.6	5.3	nA
$I_B$	Input Bias Current		●	$\pm 0.7$	$\pm 3.5$		$\pm 1.0$	$\pm 5.5$	nA
$A_{VOL}$	Large Signal Voltage Gain	$R_L \geq 2k\Omega, V_O = \pm 10V$	●	350	750		250	750	V/mV
CMRR	Common Mode Rejection Ratio	$V_{CM} = \pm 13V$	●	110	124		106	123	dB
PSRR	Power Supply Rejection Ratio	$V_S = \pm 3V$ to $\pm 18V$	●	106	120		103	120	dB
	Input Voltage Range		●	$\pm 13$	$\pm 14$		$\pm 13$	$\pm 14$	V
$V_{OUT}$	Output Voltage Swing	$R_L \geq 2k\Omega$	●	$\pm 12.5$	$\pm 13.8$		$\pm 12.5$	$\pm 13.8$	V
$P_d$	Power Dissipation	No load	●	50	85		55	90	mW

The ● denotes the specifications which apply over the full operating temperature range.

**Note 1:** Offset voltage for the LT1001AM/883 and LT1001AC are measured after power is applied and the device is fully warmed up. All other grades are measured with high speed test equipment, approximately 1 second after power is applied. The LT1001AM/883 receives 168 hr. burn-in at 125°C. or equivalent.

**Note 2:** This parameter is tested on a sample basis only.

**Note 3:** Long Term Input Offset Voltage Stability refers to the averaged trend line of  $V_{OS}$  versus Time over extended periods after the first 30 days of operation. Excluding the initial hour of operation, changes in  $V_{OS}$  during the first 30 days are typically 2.5 $\mu V$ .

**Note 4:** Parameter is guaranteed by design.

**Note 5:** 10Hz noise voltage density is sample tested on every lot. Devices 100% tested at 10Hz are available on request.

# TYPICAL PERFORMANCE CHARACTERISTICS

**Typical Distribution of Offset Voltage Drift with Temperature**

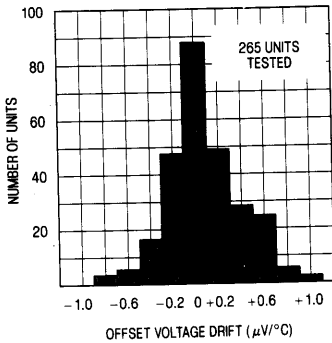

**Offset Voltage Drift with Temperature of Representative Units**

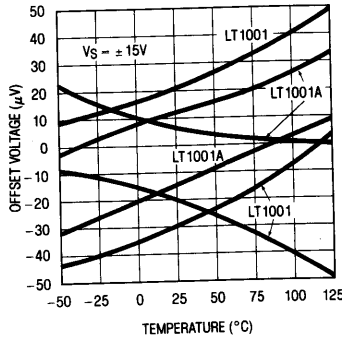

**Warm-Up Drift**

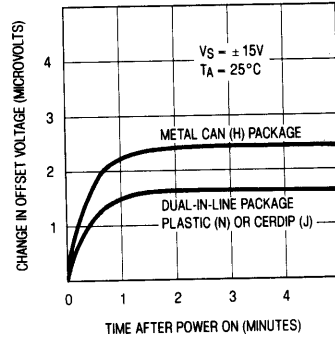

**0.1Hz to 10Hz Noise**

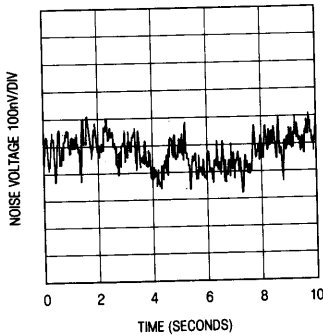

**Noise Spectrum**

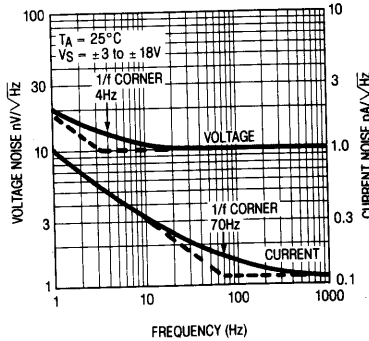

**Long Term Stability of Four Representative Units**

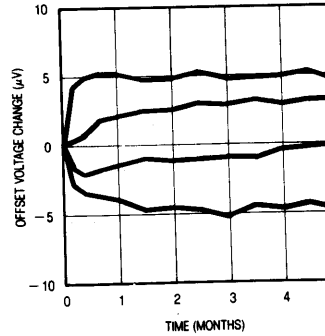

**Input Bias and Offset Current vs Temperature**

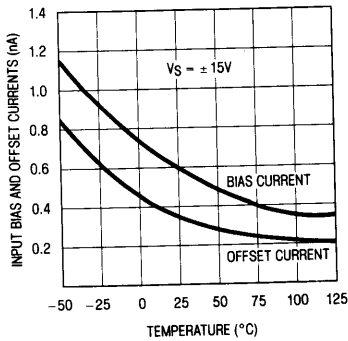

**Input Bias Current Over the Common Mode Range**

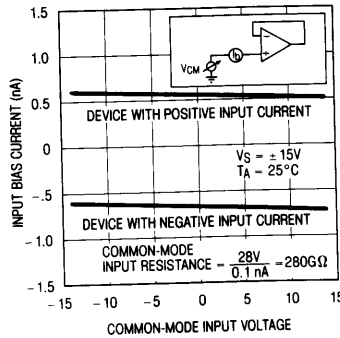

**Input Bias Current vs. Differential Input Voltage**

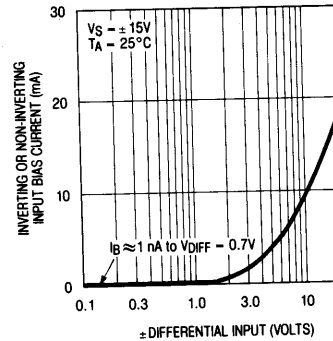

# TYPICAL PERFORMANCE CHARACTERISTICS

**Open Loop Voltage Gain vs Temperature**

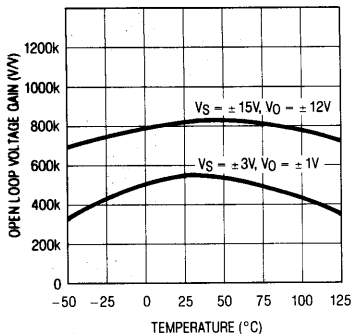

**Open Loop Voltage Gain Frequency Response**

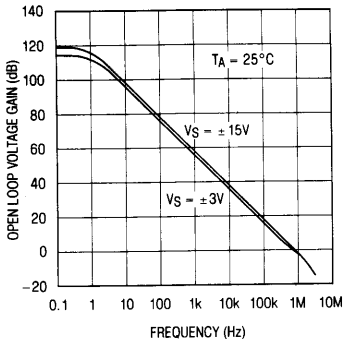

**Gain, Phase Shift vs. Frequency**

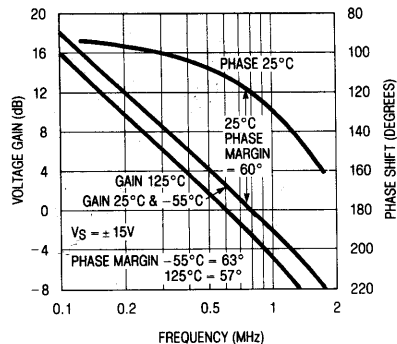

**Common Mode Limit vs Temperature**

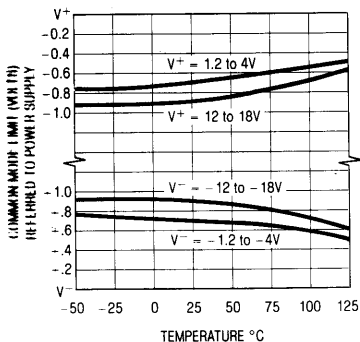

**Common Mode Rejection Ratio vs Frequency**

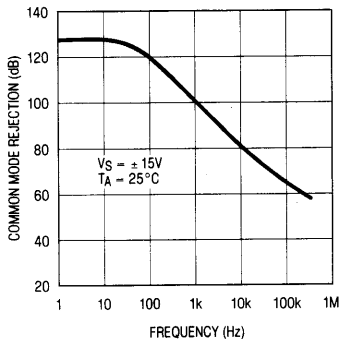

**Power Supply Rejection Ratio vs Frequency**

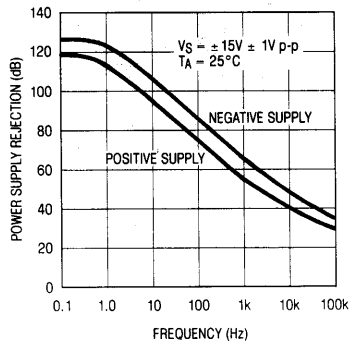

**Supply Current vs Supply Voltage**

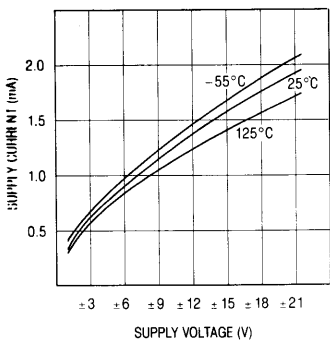

**Output Swing vs. Load Resistance**

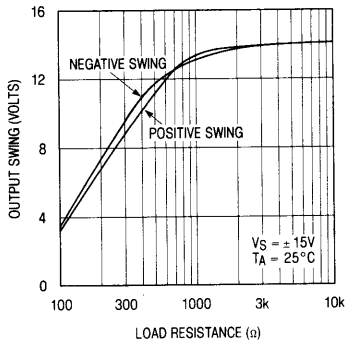

**Output Short Circuit Current vs Time**

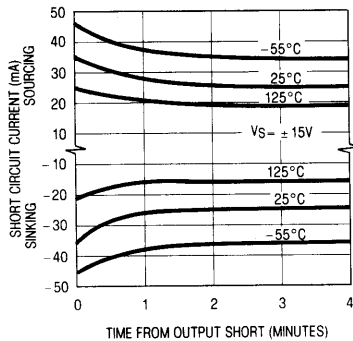

# TYPICAL PERFORMANCE CHARACTERISTICS

Small Signal Transient Response

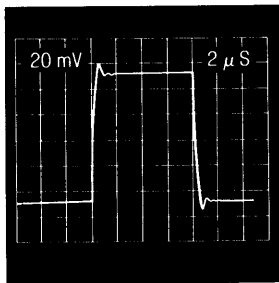

$A_v = +1$ ,  $C_L = 50\text{pF}$

Voltage Follower Overshoot vs Capacitive Load

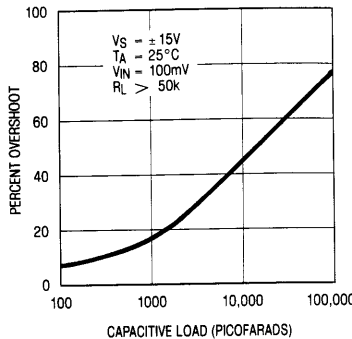

Small Signal Transient Response

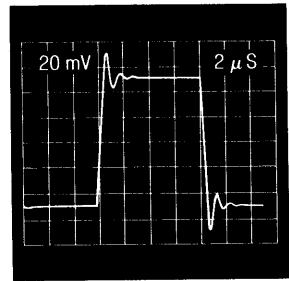

$A_v = +1$ ,  $C_L = 1000\text{pF}$

Large Signal Transient Response

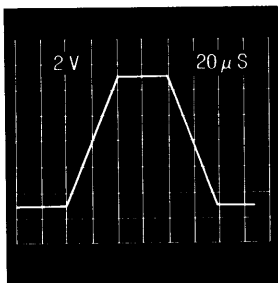

Maximum Undistorted Output vs. Frequency

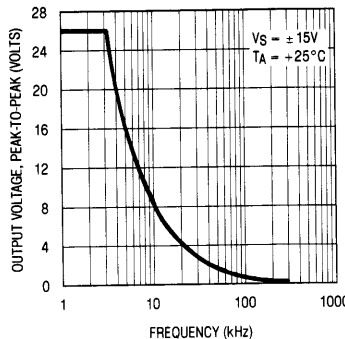

Closed Loop Output Impedance

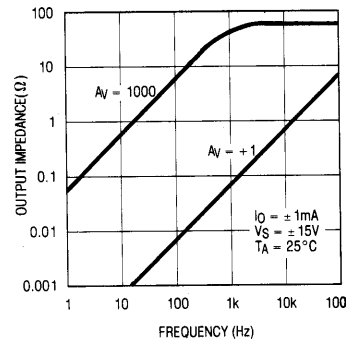

## APPLICATIONS INFORMATION

### Application Notes and Test Circuits

The LT1001 series units may be inserted directly into OP-07, OP-05, 725, 108A or 101A sockets with or without removal of external frequency compensation or nulling components. The LT1001 can also be used in 741, LF156 or OP-15 applications provided that the nulling circuitry is removed.

The LT1001 is specified over a wide range of power supply voltages from  $\pm 3\text{V}$  to  $\pm 18\text{V}$ . Operation with lower supplies is possible down to  $\pm 1.2\text{V}$  (two Ni-Cad batteries). However, with  $\pm 1.2\text{V}$  supplies, the device is stable only in closed loop gains of  $+2$  or higher (or inverting gain of one or higher).

Unless proper care is exercised, thermocouple effects caused by temperature gradients across dissimilar

metals at the contacts to the input terminals, can exceed the inherent drift of the amplifier. Air currents over device leads should be minimized, package leads should be short, and the two input leads should be as close together as possible and maintained at the same temperature.

Test Circuit for Offset Voltage and its Drift with Temperature

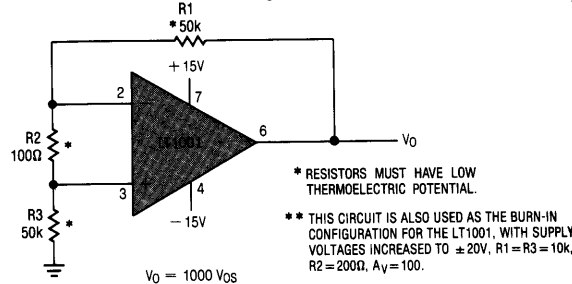

### Offset Voltage Adjustment

The input offset voltage of the LT1001, and its drift with temperature, are permanently trimmed at wafer test to a low level. However, if further adjustment of  $V_{os}$  is necessary, nulling with a 10k or 20k potentiometer will not degrade drift with temperature. Trimming to a value other than zero creates a drift of  $(V_{os}/300) \mu V/^{\circ}C$ , e.g. if  $V_{os}$  is adjusted to  $300 \mu V$ , the change in drift will be  $1 \mu V/^{\circ}C$ . The adjustment range with a 10k or 20k pot is approximately  $\pm 2.5mV$ . If less adjustment range is needed, the sensitivity and resolution of the nulling can be improved by using a smaller pot in conjunction with fixed resistors. The example below has an approximate null range of  $\pm 100 \mu V$ .

#### Improved Sensitivity Adjustment

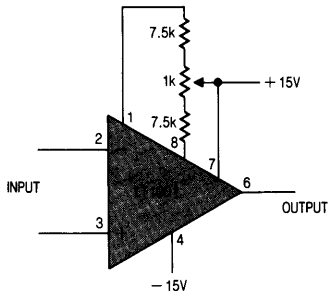

### 0.1Hz to 10Hz Noise Test Circuit

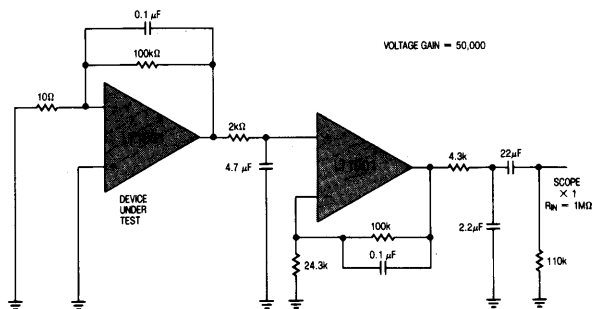

(Peak to Peak noise measured in 10 Sec interval)

The device under test should be warmed up for three minutes and shielded from air currents.

### DC Stabilized 1000V/µsec Op Amp

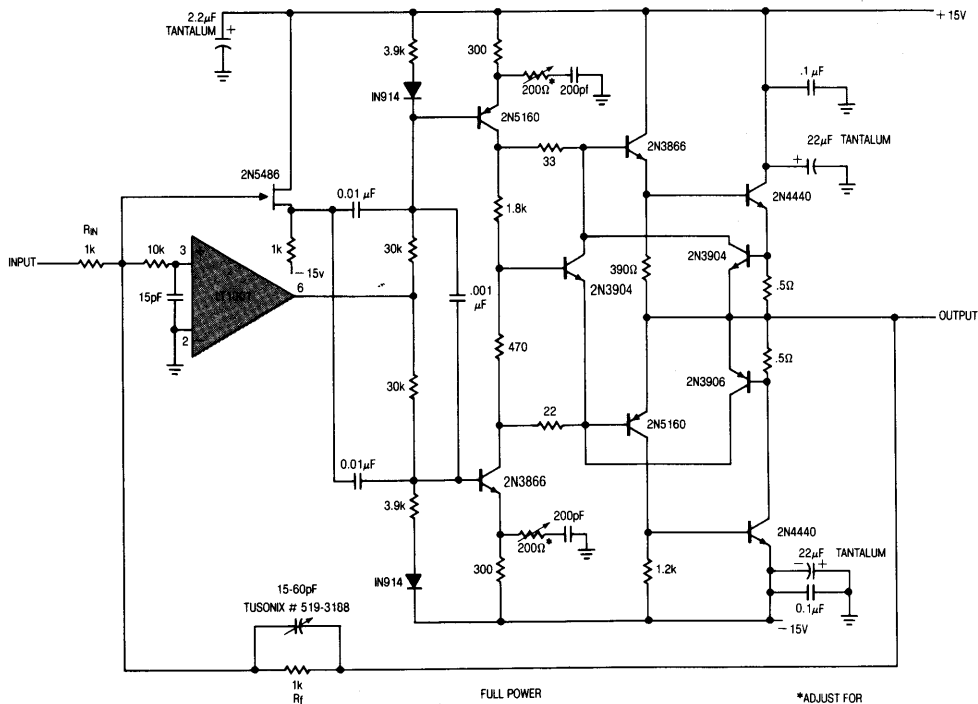

# TYPICAL APPLICATIONS

**Microvolt Comparator with TTL Output**

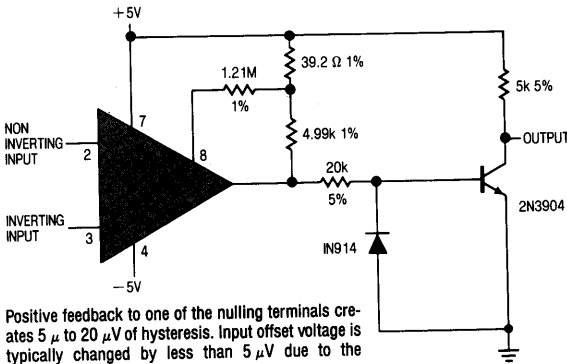

Positive feedback to one of the nulling terminals creates 5  $\mu$  to 20  $\mu$ V of hysteresis. Input offset voltage is typically changed by less than 5  $\mu$ V due to the feedback.

**Photodiode Amplifier**

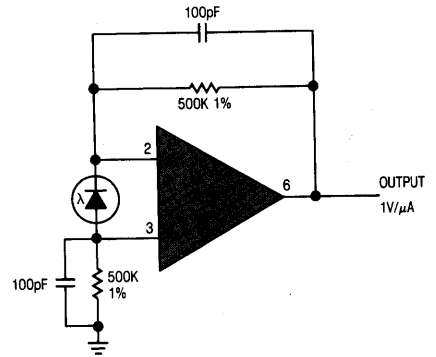

**Precision Current Source**

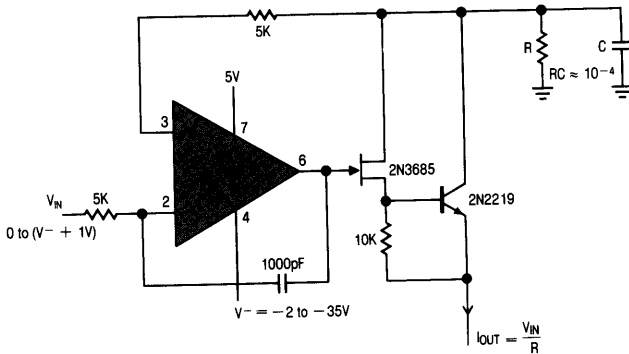

**Precision Current Sink**

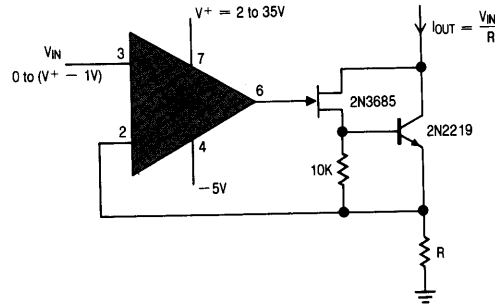

**Strain Gauge Signal Conditioner with Bridge Excitation**

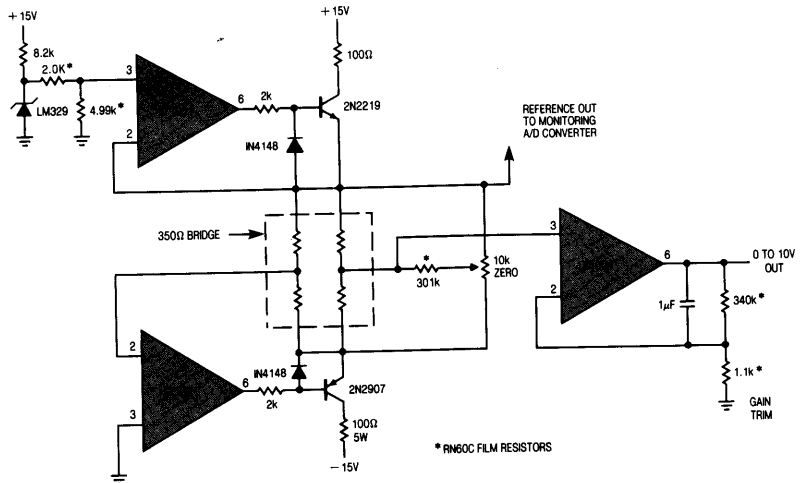

\* RN60C FILM RESISTORS



**Large Signal Voltage Follower  
With 0.001% Worst-Case Accuracy**

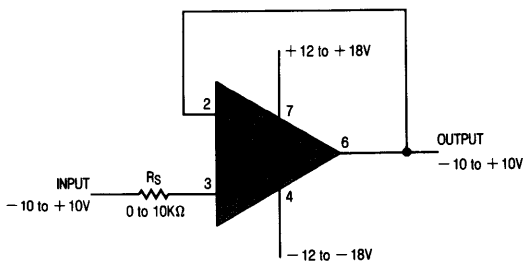

The voltage follower is an ideal example illustrating the overall excellence of the LT1001. The contributing error terms are due to offset voltage, input bias current, voltage gain, common-mode and power-supply

rejections. Worst-case summation of guaranteed specifications is tabulated below.

Error	OUTPUT ACCURACY			
	LT1001AM / 883	LT1001C	LT1001AM / 883	LT1001C
	25°C Max.	25°C Max.	-55 to 125°C Max.	0 to 70°C Max.
Offset Voltage	15μV	60μV	60μV	110μV
Bias Current	20μV	40μV	40μV	55μV
Common-Mode Rejection	20μV	30μV	30μV	50μV
Power Supply Rejection	18μV	30μV	36μV	42μV
Voltage Gain	22μV	25μV	33μV	40μV
Worst-case Sum Percent of Full Scale (=20V)	95μV 0.0005%	185μV 0.0009%	199μV 0.0010%	297μV 0.0015%

**Thermally Controlled Nicad Charger**

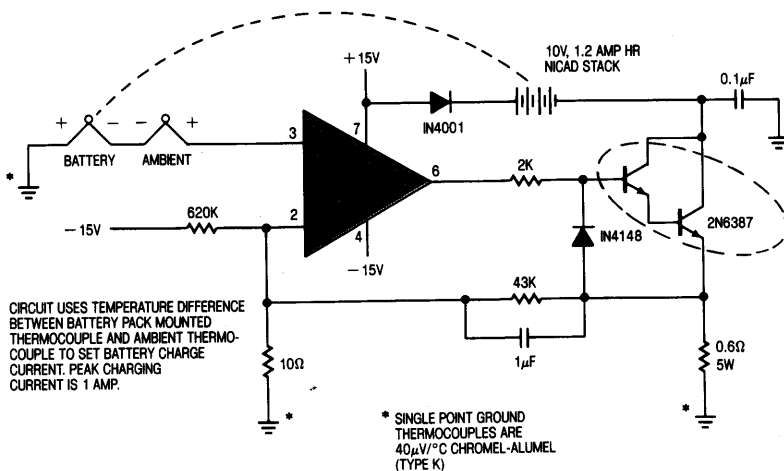

**Precision Absolute Value Circuit**

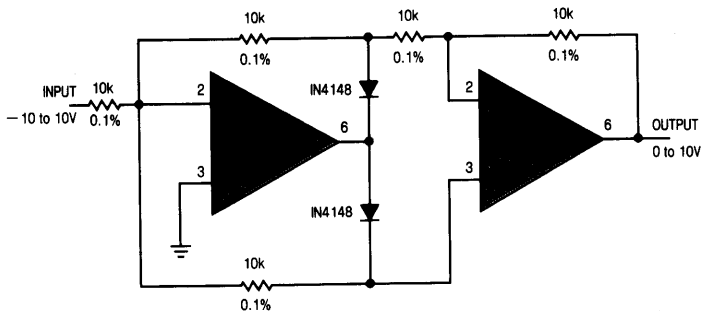



**Instrumentation Amplifier with  $\pm 300V$   
Common Mode Range and CMRR > 150dB**

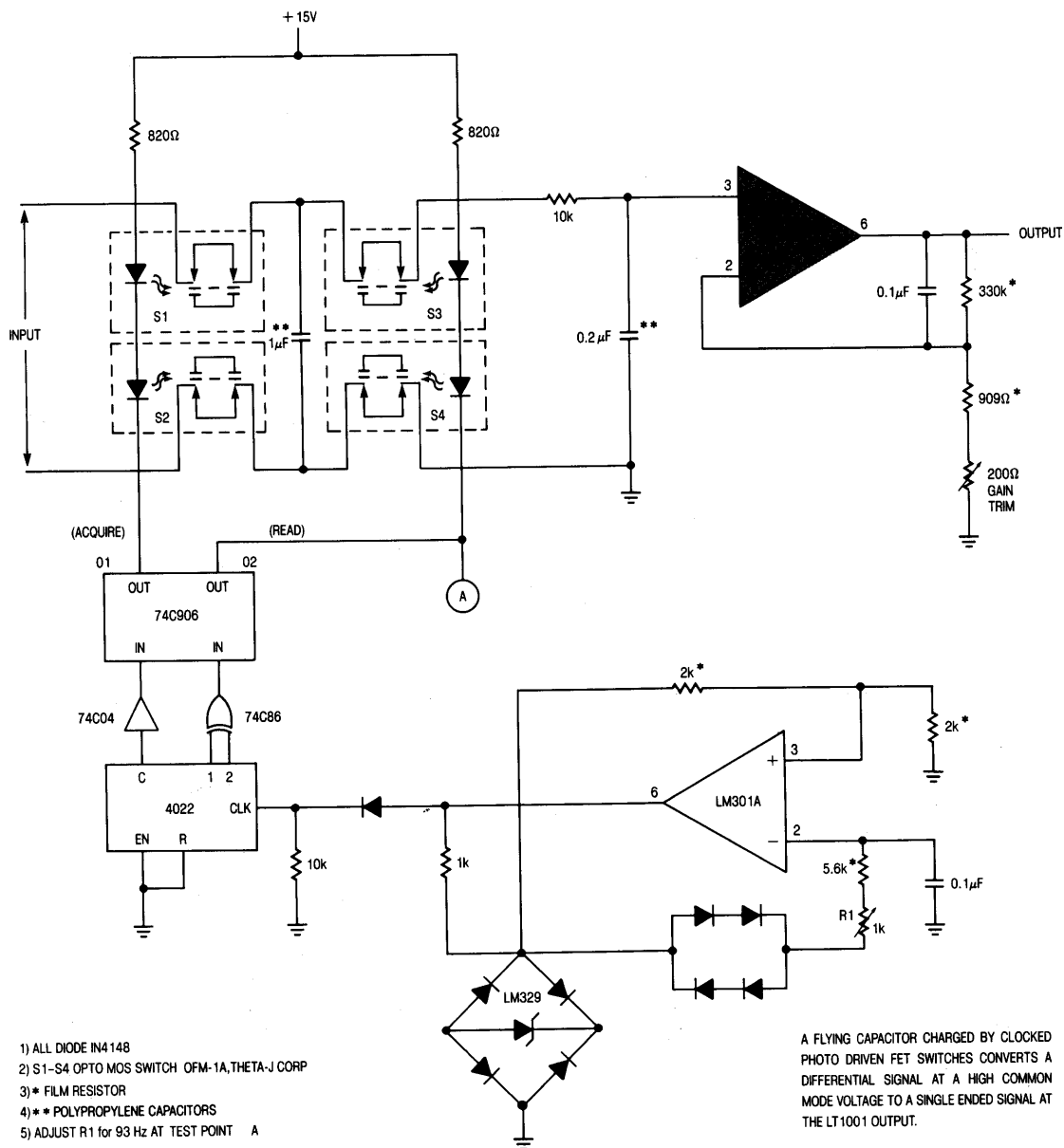

- 1) ALL DIODE IN4148
- 2) S1-S4 OPTO MOS SWITCH OFM-1A, THETA-J CORP
- 3)\* FILM RESISTOR
- 4)\* POLYPROPYLENE CAPACITORS
- 5) ADJUST R1 for 93 Hz AT TEST POINT A

A FLYING CAPACITOR CHARGED BY CLOCKED PHOTO DRIVEN FET SWITCHES CONVERTS A DIFFERENTIAL SIGNAL AT A HIGH COMMON MODE VOLTAGE TO A SINGLE ENDED SIGNAL AT THE LT1001 OUTPUT.

Verbley de 11/8/09

# LT1001

## SCHEMATIC DIAGRAM

LT1001 Schematic Diagram

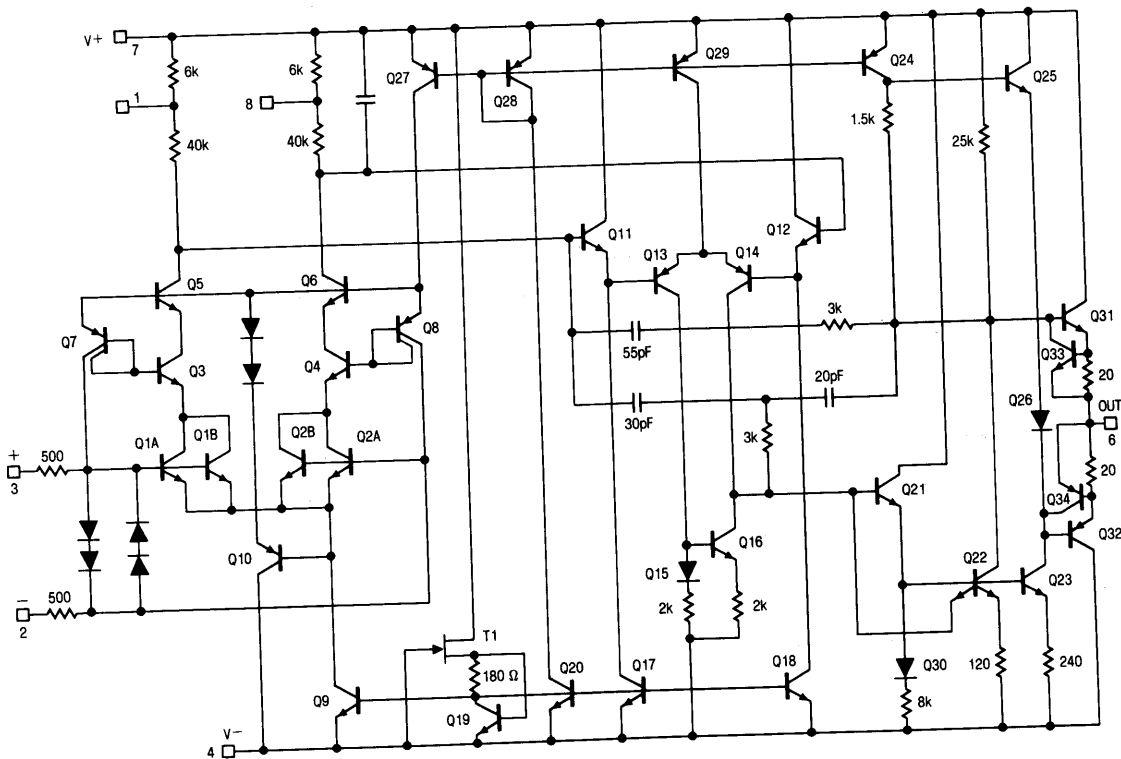

## PACKAGE DESCRIPTION

**H Package**  
Metal Can

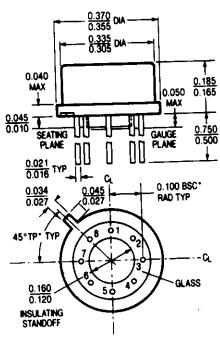

NOTE: DIMENSIONS IN INCHES

$T_j$ max	$\theta_{ja}$	$\theta_{jc}$
150°C	150°C/W	45°C/W

**J8 Package**  
8 Lead Hermetic Dip

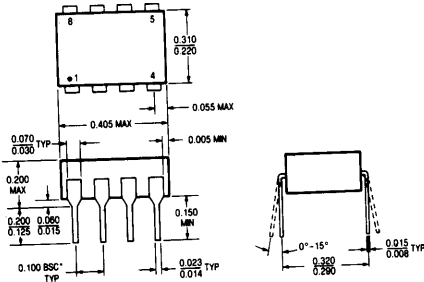

NOTE: DIMENSIONS IN INCHES UNLESS OTHERWISE NOTED  
\*LEADS WITHIN 0.007 OF TRUE POSITION (TP) AT GAUGE PLANE

$T_j$ max	$\theta_{ja}$
150°C	100°C/W

**N8 Package**  
8 Lead Plastic

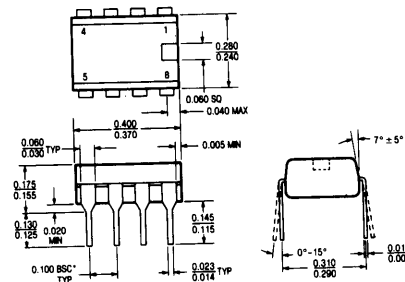

NOTE: DIMENSIONS IN INCHES UNLESS OTHERWISE NOTED  
\*LEADS WITHIN 0.007 OF TRUE POSITION (TP) AT GAUGE PLANE

$T_j$ max	$\theta_{ja}$
100°C	130°C/W