

## FEATURES

- Single Supply Operation
  - Input Voltage Range Extends to Ground
  - Output Swings to Ground while Sinking Current
- *Guaranteed* Offset Voltage 50 $\mu$ V Max.
- *Guaranteed* Low Drift 1.3 $\mu$ V/ $^{\circ}$ C Max.
- *Guaranteed* Offset Current 0.5nA Max.
- *Guaranteed* High Gain
  - 5mA Load Current 1.5 Million Min.
  - 17mA Load Current 0.8 Million Min.
- *Guaranteed* Low Supply Current 520 $\mu$ A Max.
- Supply Current can be Reduced by a Factor of 4
- Low Voltage Noise, 0.1Hz to 10Hz 0.55 $\mu$ Vp-p
- Low Current Noise—
  - Better than OP-07 0.07pA/ $\sqrt{\text{Hz}}$  at 10Hz
- High Input Impedance 250M $\Omega$  Min.
- *Guaranteed* Minimum Supply Voltage 2.7V Min.

## APPLICATIONS

- Low Power Sample and Hold Circuits
- Battery Powered Precision Instrumentation
  - Strain Gauge Signal Conditioners
  - Thermocouple Amplifiers
- 4mA–20mA Current Loop Transmitters
- Active Filters

## DESCRIPTION

The LT1006 is the first precision single supply operational amplifier. Its design has been optimized for single supply operation with a full set of specifications at 5V. Specifications at  $\pm 15$ V are also provided.

The LT1006 has low offset voltage of 20 $\mu$ V, drift of 0.2 $\mu$ V/ $^{\circ}$ C, offset current of 120pA, gain of 2.5 million, common-mode rejection of 114dB, and power supply rejection of 126dB.

Although supply current is only 340 $\mu$ A, a novel output stage can source or sink in excess of 20mA while retaining high voltage gain. Common-mode input range includes ground to accommodate low ground-referenced inputs from strain gauges or thermocouples, and output can swing to within a few millivolts of ground. If higher slew rate (in excess of 1V/ $\mu$ s) or micropower operation (supply current down to 90 $\mu$ A) is required, the operating currents can be modified by connecting an external optional resistor to Pin 8.

For similar single supply precision dual and quad op amps, please see the LT1013/LT1014 data sheet. For micropower dual and quad op amps, please see the LT1078/LT1079 data sheet.

2

LT1006 Single Supply, Micropower Sample and Hold

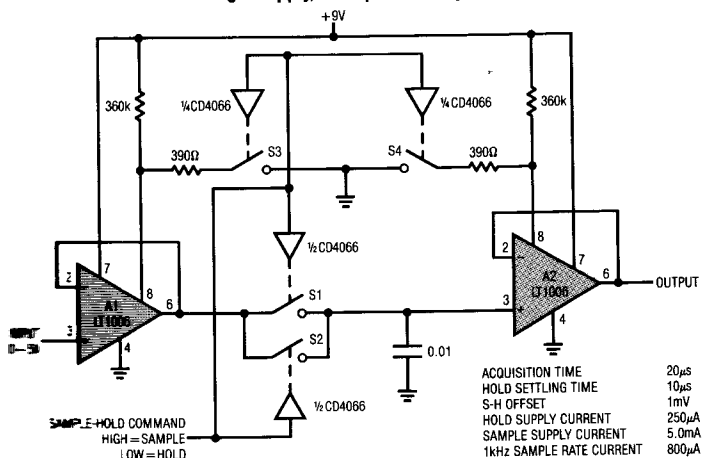

Distribution of Input Offset Voltage

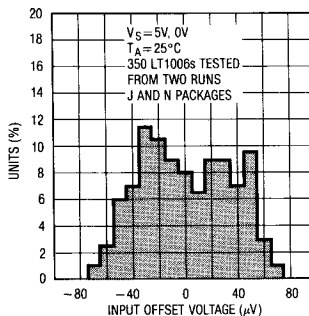

**ABSOLUTE MAXIMUM RATINGS**

Supply Voltage ..... ± 22V  
 Input Voltage ..... Equal to Positive Supply Voltage  
 ..... 5V Below Negative Supply Voltage  
 Differential Input Voltage ..... 30V  
 Output Short Circuit Duration ..... Indefinite  
 Operating Temperature Range  
 LT1006AM, M ..... -55°C to 125°C  
 LT1006AC, C ..... 0°C to 70°C  
 Storage Temperature Range  
 All Devices ..... -65°C to 150°C  
 Lead Temperature (Soldering, 10 sec) ..... 300°C

**PACKAGE/ORDER INFORMATION**

<p>TOP VIEW  <math>I_{SY}</math> SET (NOTE 2)  <math>V_{OS}</math> TRIM  <math>V_{OS}</math> TRIM (NOTE 4)                  H8 PACKAGE TO-5 METAL CAN</p>	ORDER PART NUMBER
	LT1006AMH LT1006MH LT1006ACH LT1006CH
<p>TOP VIEW  <math>V_{OS}</math> TRIM  <math>I_{SY}</math> SET  <math>V_{OS}</math> TRIM (NOTE 4)                  J8 PACKAGE HERMETIC DIP                  N8 PACKAGE PLASTIC DIP</p>	ORDER PART NUMBER
	LT1006AMJ8 LT1006MJ8 LT1006ACJ8 LT1006CJ8 LT1006CN8

**ELECTRICAL CHARACTERISTICS**  $V_S = 5V, V_{CM} = 0V, V_{OUT} = 1.4V, T_A = 25^\circ C$ , unless otherwise noted.

SYMBOL	PARAMETER	CONDITIONS	LT1006AM/AC			LT1006M/C		UNITS	
			MIN	TYP	MAX	MIN	TYP		MAX
$V_{OS}$	Input Offset Voltage			20	50		30	80	$\mu V$
$\frac{\Delta V_{OS}}{\Delta Time}$	Long Term Input Offset Voltage Stability			0.4			0.5		$\mu V/Mo$
$I_{OS}$	Input Offset Current			0.12	0.5		0.15	0.9	nA
$I_B$	Input Bias Current			9	15		10	25	nA
$e_n$	Input Noise Voltage	0.1Hz to 10Hz		0.55			0.55		$\mu V-p-p$
	Input Noise Voltage Density	$f_o = 10Hz$ (Note 3) $f_o = 1000Hz$ (Note 3)		23	32		23	32	$nV/\sqrt{Hz}$ $nV/\sqrt{Hz}$
$i_n$	Input Noise Current Density	$f_o = 10Hz$		0.07			0.08		$pA/\sqrt{Hz}$
	Input Resistance	(Note 1)	180	400		100	300		$M\Omega$
	Differential Mode			5			4		$G\Omega$
	Common-Mode								
	Input Voltage Range		3.5	3.8		3.5	3.8		V
			0	-0.3		0	-0.3		V
CMRR	Common-Mode Rejection Ratio	$V_{CM} = 0V$ to 3.5V	100	114		97	112		dB
PSRR	Power Supply Rejection Ratio	$V_S = \pm 2V$ to $\pm 18V, V_O = 0V$	106	126		103	124		dB
$A_{VOL}$	Large Signal Voltage Gain	$V_O = 0.03V$ to 4V, $R_L = 10k$ $V_O = 0.03V$ to 3.5V, $R_L = 2k$	1.0	2.5		0.7	2.0		$V/\mu V$ $V/\mu V$
	Maximum Output Voltage Swing	Output Low, No Load Output Low, 6000 $\Omega$ to GND Output Low, $I_{SINK} = 1mA$ Output High, No Load Output High, 6000 $\Omega$ to GND		15	25		15	25	mV
				5	10		5	10	mV
				220	350		220	350	mV
			4.0	4.4		4.0	4.4		V
			3.4	4.0		3.4	4.0		V
SR	Slew Rate		0.25	0.4		0.25	0.4		$V/\mu s$
$I_S$	Supply Current	$R_{SET} = \infty$ $R_{SET} = 180k$ Pin 8 to Pin 7 (Note 2)		340	520		350	570	$\mu A$ $\mu A$
				90			90		$\mu A$
	Minimum Supply Voltage		2.7			2.7			V

## ELECTRICAL CHARACTERISTICS

$V_S = 5V, 0V, V_{CM} = 0.1V, V_O = 1.4V, -55^\circ C \leq T_A \leq 125^\circ C$ , unless otherwise noted.

SYMBOL	PARAMETER	CONDITIONS	LT1006AM			LT1006M			UNITS
			MIN	TYP	MAX	MIN	TYP	MAX	
$V_{OS}$	Input Offset Voltage		●	40	180	60	250	$\mu V$	
$\frac{\Delta V_{OS}}{\Delta Temp}$	Input Offset Voltage Drift		●	0.2	1.3	0.3	1.8	$\mu V/^\circ C$	
$I_{OS}$	Input Offset Current		●	0.4	2.0	0.5	4.0	nA	
$I_B$	Input Bias Current		●	13	25	16	40	nA	
$A_{VOL}$	Large Signal Voltage Gain	$V_O = 0.05V$ to $3.5V, R_L = 2k$	●	0.25	0.8	0.15	0.7	$V/\mu V$	
CMRR	Common-Mode Rejection Ratio	$V_{CM} = 0.1V$ to $3.2V$	●	90	103	87	102	dB	
PSRR	Power Supply Rejection Ratio	$V_S = \pm 2V$ to $\pm 18V, V_O = 0V$	●	100	117	97	116	dB	
	Maximum Output Voltage Swing	Output Low, 6000 to GND Output High, 6000 to GND	● ●	6 3.2	15 3.8	6 3.1	18 3.8	mV V	
$I_S$	Supply Current		●	380	630	400	680	$\mu A$	

2

## ELECTRICAL CHARACTERISTICS

$V_S = 5V, 0V, V_{CM} = 0V, V_O = 1.4V, 0^\circ C \leq T_A \leq 70^\circ C$ , unless otherwise noted.

SYMBOL	PARAMETER	CONDITIONS	LT1006AC			LT1006C			UNITS
			MIN	TYP	MAX	MIN	TYP	MAX	
$V_{OS}$	Input Offset Voltage	LT1006N8	● ●	30	110	45	160	$\mu V$ $\mu V$	
$\frac{\Delta V_{OS}}{\Delta Temp}$	Input Offset Voltage Drift	LT1006N8	● ●	0.2	1.3	0.3	1.8	$\mu V/^\circ C$ $\mu V/^\circ C$	
$I_{OS}$	Input Offset Current		●	0.25	1.2	0.3	2.5	nA	
$I_B$	Input Bias Current		●	11	20	12	30	nA	
$A_{VOL}$	Large Signal Voltage Gain	$V_O = 0.04V$ to $3.5V, R_L = 2k$	●	0.35	1.3	0.25	1.2	$V/\mu V$	
CMRR	Common-Mode Rejection Ratio	$V_{CM} = 0V$ to $3.4V$	●	96	109	92	108	dB	
PSRR	Power Supply Rejection Ratio	$V_S = \pm 2V$ to $\pm 18V, V_O = 0V$	●	101	120	97	118	dB	
	Maximum Output Voltage Swing	Output Low, 6000 to GND Output High, 6000 to GND	● ●	6 3.3	13 3.9	6 3.2	13 3.9	mV V	
$I_S$	Supply Current		●	350	570	360	620	$\mu A$	

The ● denotes the specifications which apply over the full operating temperature range.

**Note 1:** This parameter is guaranteed by design and is not tested.

**Note 2:** Regular operation does not require an external resistor. In order to program the supply current for low power or high speed operation, connect an external resistor from Pin 8 to Pin 7 or from Pin 8 to Pin 4, respectively.

Supply current specifications (for  $R_{SET} = 180k$ ) do not include current in  $I_{OS}$ .

**Note 3:** This parameter is tested on a sample basis only. All noise parameters are tested with  $V_S = \pm 2.5V, V_O = 0V$ .

**Note 4:** Optional offset nulling is accomplished with a potentiometer connected between the trim terminals and the wiper to  $V^-$ . A 10k pot (providing a null range of  $\pm 6mV$ ) is recommended for minimum drift of nulled offset voltage with temperature. For increased trim resolution and accuracy, two fixed resistors can be used in conjunction with a smaller potentiometer. For example: two 4.7k resistors tied to pins 1 and 5, with a 5000 pot in the middle, will have a null range of  $\pm 150\mu V$ .

**ELECTRICAL CHARACTERISTICS**  $V_S = \pm 15V, T_A = 25^\circ C$ , unless otherwise noted.

SYMBOL	PARAMETER	CONDITIONS	LT1006AM/AC			LT1006M/C			UNITS
			MIN	TYP	MAX	MIN	TYP	MAX	
$V_{OS}$	Input Offset Voltage			30	100		50	180	$\mu V$
$I_{OS}$	Input Offset Current			0.1	0.5		0.15	0.9	nA
$I_B$	Input Bias Current			7.5	12.0		8.0	20.0	nA
	Input Voltage Range		13.5 -15.0	13.8 -15.3		13.5 -15.0	13.8 -15.3		V
CMRR	Common-Mode Rejection Ratio	$V_{CM} = +13.5V, -15V$	100	117		97	116		dB
PSRR	Power Supply Rejection Ratio	$V_S = \pm 2V$ to $\pm 18V, V_O = 0V$	106	126		103	124		dB
$A_{VOL}$	Large Signal Voltage Gain	$V_O = \pm 10V, R_L = 2k$ $V_O = \pm 10V, R_L = 600\Omega$	1.5 0.8	5.0 1.5		1.2 0.5	4.0 1.0		$V/\mu V$ $V/\mu V$
$V_{OUT}$	Maximum Output Voltage Swing	$R_L = 2k$	$\pm 13$	$\pm 14$		$\pm 12.5$	$\pm 14$		V
SR	Slew Rate	$R_{SET} = \infty$ $R_{SET} = 390\Omega$ Pin 8 to Pin 4	0.25 1.0	0.4 1.2		0.25 1.0	0.4 1.2		$V/\mu S$ $V/\mu S$
$I_S$	Supply Current			360 540		360 600			$\mu A$

**ELECTRICAL CHARACTERISTICS**  $V_S = \pm 15V, -55^\circ C \leq T_A \leq 125^\circ C$ , unless otherwise noted.

SYMBOL	PARAMETER	CONDITIONS	LT1006AM			LT1006M			UNITS
			MIN	TYP	MAX	MIN	TYP	MAX	
$V_{OS}$	Input Offset Voltage			80	320		110	460	$\mu V$
$\Delta V_{OS}$	Input Offset Voltage Drift			0.5	2.2		0.6	2.8	$\mu V/^\circ C$
$\Delta Temp$									
$I_{OS}$	Input Offset Current			0.2	2.0		0.3	3.0	nA
$I_B$	Input Bias Current			9	18		11	27	nA
$A_{VOL}$	Large Signal Voltage Gain	$V_O = \pm 10V, R_L = 2k$		0.5	1.5		0.25	1.0	$V/\mu V$
CMRR	Common-Mode Rejection Ratio	$V_{CM} = +13V, -14.9V$		97	114		94	113	dB
PSRR	Power Supply Rejection Ratio	$V_S = \pm 2V$ to $\pm 18V, V_O = 0V$		100	117		97	116	dB
	Maximum Output Voltage Swing	$R_L = 2k$		$\pm 12$	$\pm 13.8$		$\pm 11.5$	$\pm 13.8$	V
$I_S$	Supply Current			400	650		400	750	$\mu A$

**ELECTRICAL CHARACTERISTICS**  $V_S = \pm 15V, 0^\circ C \leq T_A \leq 70^\circ C$ , unless otherwise noted.

SYMBOL	PARAMETER	CONDITIONS	LT1006AC			LT1006C			UNITS
			MIN	TYP	MAX	MIN	TYP	MAX	
$V_{OS}$	Input Offset Voltage	LT1006N8		50	200		75	300	$\mu V$
$\Delta V_{OS}$	Input Offset Voltage Drift	LT1006N8		0.5	2.2		0.6	2.8	$\mu V/^\circ C$
$\Delta Temp$							0.7	3.5	$\mu V/^\circ C$
$I_{OS}$	Input Offset Current			0.15	1.0		0.25	2.0	nA
$I_B$	Input Bias Current			8.0	15		10	23	nA
$A_{VOL}$	Large Signal Voltage Gain	$V_O = \pm 10V, R_L = 2k$		1.0	3.0		0.7	2.5	$V/\mu V$
CMRR	Common-Mode Rejection Ratio	$V_{CM} = 13V, -15V$		98	116		94	114	dB
PSRR	Power Supply Rejection Ratio	$V_S = \pm 2V$ to $\pm 18V, V_O = 0V$		101	120		97	118	dB
	Maximum Output Voltage Swing	$R_L = 2k$		$\pm 12.5$	$\pm 13.9$		$\pm 11.5$	$\pm 13.8$	V
$I_S$	Supply Current			370	600		380	660	$\mu A$

# TYPICAL PERFORMANCE CHARACTERISTICS

**Offset Voltage Drift with Temperature of Representative Units**

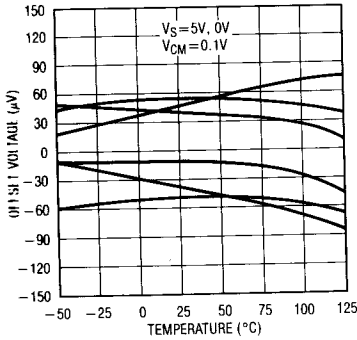

**Offset Voltage vs Balanced Source Resistor**

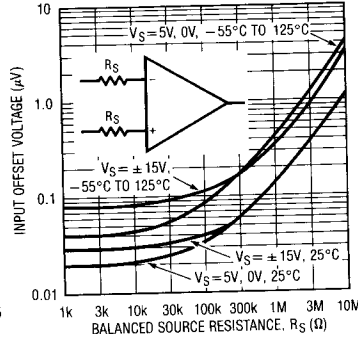

**V<sub>OS</sub> vs Common-Mode Voltage vs Temperature**

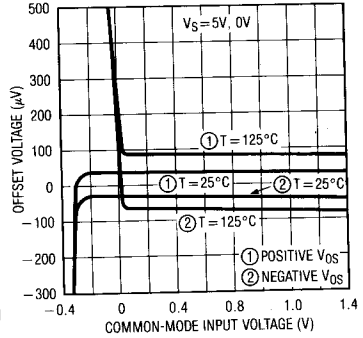

**Warm-Up Drift**

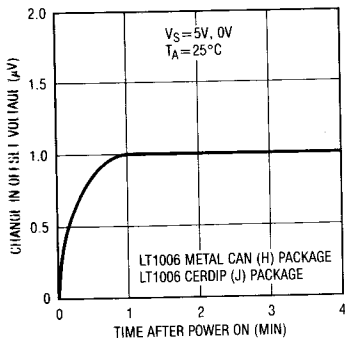

**Voltage Gain vs Load Resistance, V<sub>S</sub> = 5V, 0V**

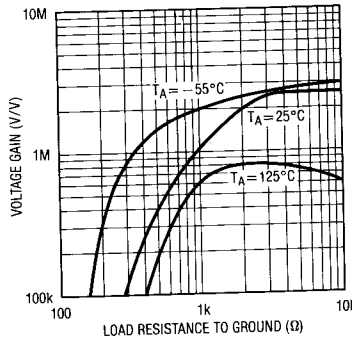

**Voltage Gain vs Load Resistance with V<sub>S</sub> = ±15V**

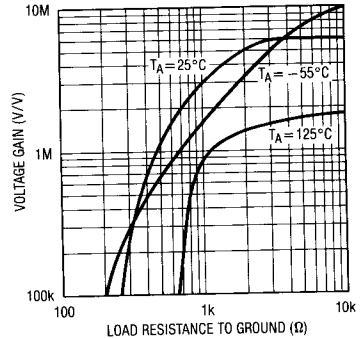

**Input Bias Current vs Temperature**

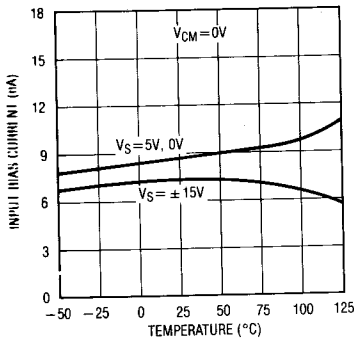

**Input Offset Current vs Temperature**

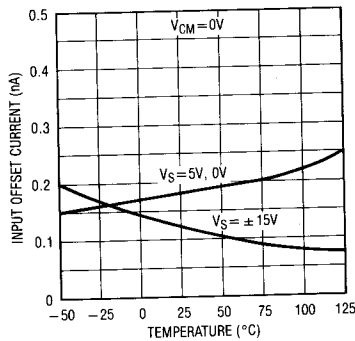

**Input Bias Current vs Common-Mode Voltage**

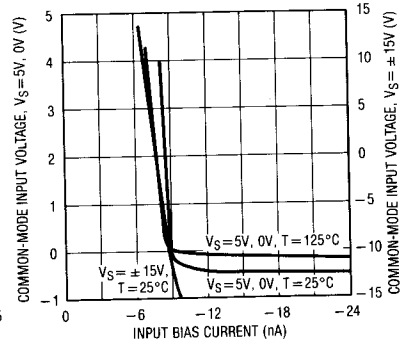

**TYPICAL PERFORMANCE CHARACTERISTICS**

**10Hz Voltage Noise Distribution**

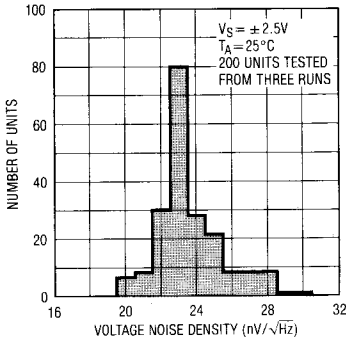

**Noise Spectrum**

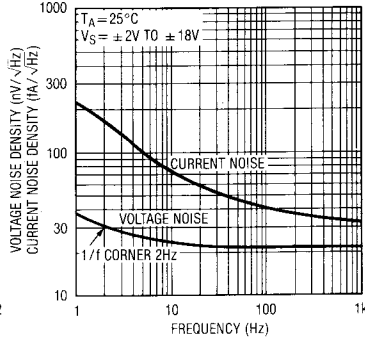

**0.1Hz to 10Hz Noise**

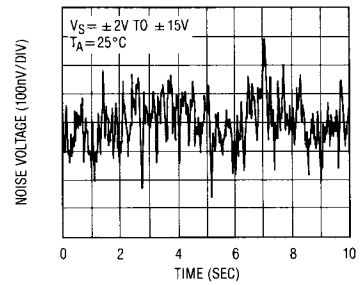

**Supply Current vs Temperature**

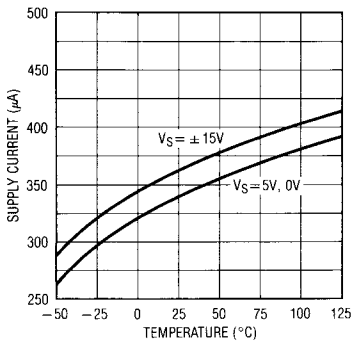

**Reducing Power Dissipation**

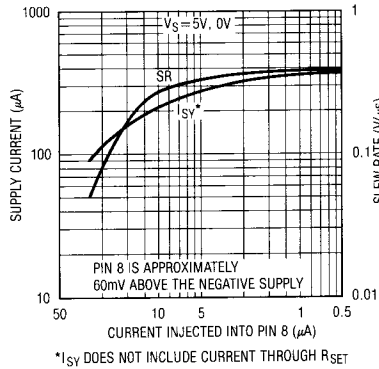

**Increasing Slew Rate (RSET to V-)**

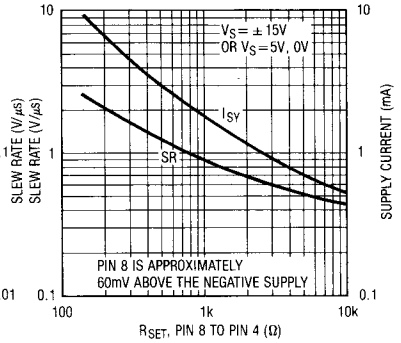

**Output Saturation vs Sink Current vs Temperature**

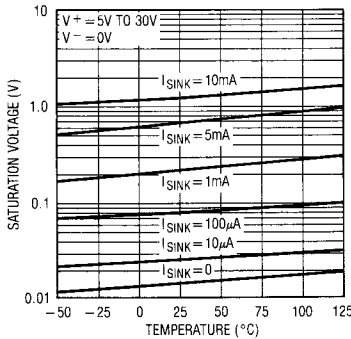

**Maximum Output Swing vs Load Resistor**

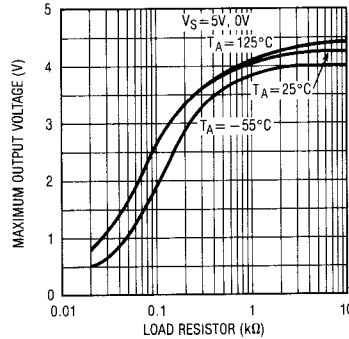

**Common-Mode Rejection Ratio vs Frequency**

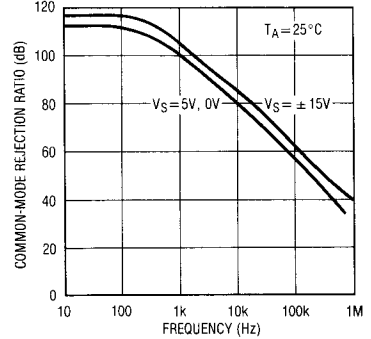

# TYPICAL PERFORMANCE CHARACTERISTICS

Voltage Gain vs Frequency

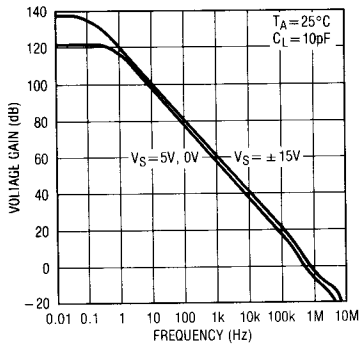

Gain, Phase vs Frequency

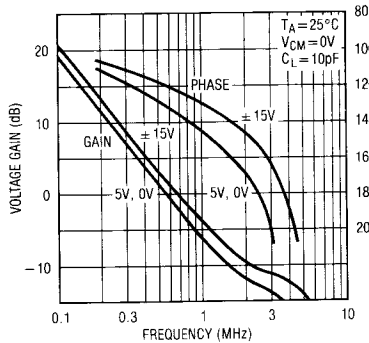

Power Supply Rejection Ratio vs Frequency

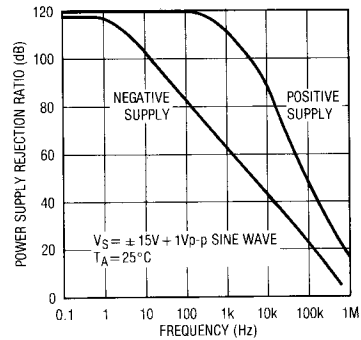

2

Large Transient Response, VS = 5V, 0V

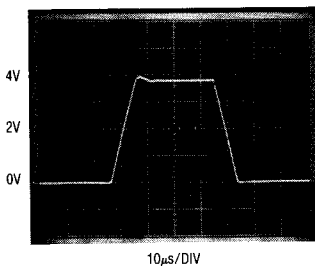

$A_V = 1$   
 $R_L = 4.7k$  TO 5V  
 INPUT = 0V TO 3.8V

Large Signal Transient Response, VS = 5V, 0V

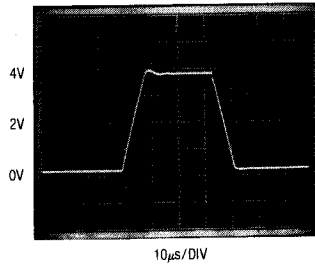

$A_V = 1$   
 $R_L = 4.7k$  TO GROUND  
 INPUT = 0V TO 3.8V

Large Signal Transient Response, VS = ±15V

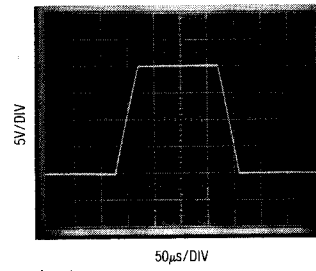

$A_V = 1$

Small Signal Transient Response, VS = 5V, 0V

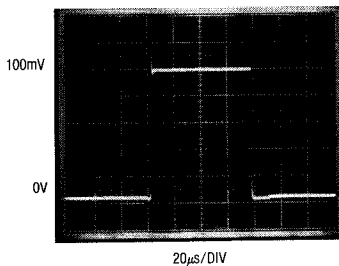

$A_V = 1$   
 $C_L = 10pF$   
 $R_L = 600\Omega$  TO GND  
 INPUT = 0V TO 100mV PULSE

Small Signal Transient Response, VCC = ±2.5V to ±15V

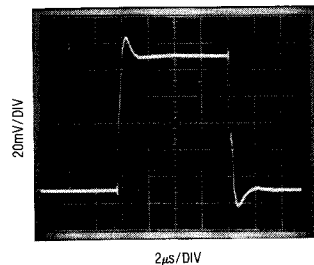

$A_V = 1$   
 $C_L = 10pF$

## APPLICATIONS INFORMATION

The LT1006 is fully specified for single supply operation, i.e., when the negative supply is 0V. Input common-mode range includes ground; the output swings within a few millivolts of ground. Single supply operation, however, can create special difficulties, both at the input and at the output. The LT1006 has specific circuitry which addresses these problems.

At the input, the driving signal can fall below 0V—inadvertently or on a transient basis. If the input is more than a few hundred millivolts below ground, two distinct problems can occur on previous single supply designs, such as the LM124, LM158, OP-20, OP-21, OP-220, OP-221, OP-420:

- a) When the input is more than a diode drop below ground, unlimited current will flow from the substrate ( $V^-$  terminal) to the input. This can destroy the unit. On the LT1006, the 400Ω resistors, in series with the input (see schematic diagram), protect the devices even when the input is 5V below ground.
- b) When the input is more than 400mV below ground (at 25°C), the input stage saturates (transistors Q3 and Q4)

and phase reversal occurs at the output. This can cause lock-up in servo systems. Due to a unique phase reversal protection circuitry (Q21, Q22, Q27, Q28), the LT1006's output does not reverse, as illustrated below, even when the inputs are at -1.5V.

At the output, the aforementioned single supply designs either cannot swing to within 600mV of ground (OP-20) or cannot sink more than a few microamperes while swinging to ground (LM124, LM158). The LT1006's all-NPN output stage maintains its low output resistance and high gain characteristics until the output is saturated.

In dual supply operations, the output stage is crossover distortion-free.

Since the output cannot go exactly to ground, but can only approach ground to within a few millivolts, care should be exercised to ensure that the output is not saturated. For example, a 1mV input signal will cause the amplifier to set up in its linear region in the gain 100 configuration shown below, but is not enough to make the amplifier function properly in the voltage follower mode.

Voltage Follower with Input Exceeding the Negative Common-Mode Range ( $V_S = 5V, 0V$ )

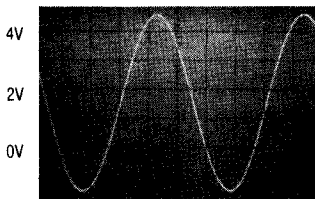

6Vp-p INPUT, -1.5V TO 4.5V

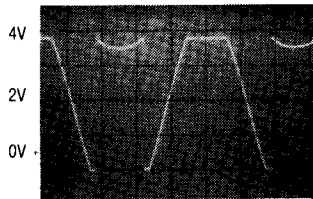

LM324, LM358, OP-20, OP-21  
EXHIBIT OUTPUT PHASE  
REVERSAL

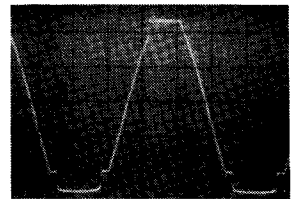

LT1006  
NO PHASE REVERSAL

Gain 100 Amplifier

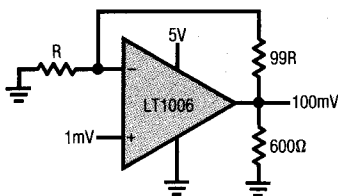

Voltage Follower

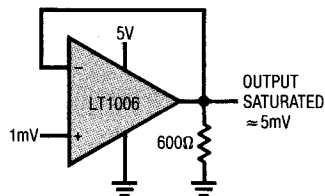



## APPLICATIONS INFORMATION

In automated production testing the output is forced to 1.4V by the test loop; offset voltage is measured with a common-mode voltage of zero and the negative supply at zero (Pin 4). Without the test loop, these exact conditions cannot be achieved. The test circuit shown ensures that the output will never saturate even with worst-case offset voltages ( $-250\mu\text{V}$  over the  $-55^\circ\text{C}$  to  $125^\circ\text{C}$  range). The effective common-mode input is 0.3V with respect to the negative supply. As indicated by the common-mode rejection specifications the difference is only a few microvolts between the two methods of offset voltage measurement.

**Test Circuit for Offset Voltage and Offset Drift with Temperature**

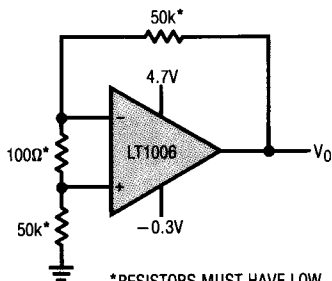

\*RESISTORS MUST HAVE LOW THERMOELECTRIC POTENTIAL.

\*\*THIS CIRCUIT IS ALSO USED AS THE BURN-IN CONFIGURATION, WITH SUPPLY VOLTAGES INCREASED TO  $\pm 20\text{V}$ .

$V_0 = 1000V_{OS}$

### Low Supply Operation

The minimum guaranteed supply voltage for proper operation of the LT1006 is 2.7V. Typical supply current at this voltage is  $320\mu\text{A}$ , therefore power dissipation is only  $860\mu\text{W}$ .

### Noise Testing

For application information on noise testing and calculations, please see the LT1007 or LT1028 data sheet.

### Supply Current Programming

Connecting an optional external resistor to Pin 8 changes the biasing of the LT1006 in order to increase its speed or to decrease its power consumption. If higher slew rate is required, connect the external resistor from Pin 8 to Pin 4 [see performance curves for Increasing Slew Rate ( $R_{SET}$  to  $V^-$ )]. For lower power consumption, inject a current into Pin 8 (which is approximately 60mV above  $V^-$ ) as shown on the Reducing Power Dissipation plot. This can be accomplished by connecting  $R_{SET}$  to the positive supply, or to save additional power, by obtaining the injected current from a low voltage battery.

### Comparator Applications

The single supply operation of the LT1006 and its ability to swing close to ground while sinking current lends itself to use as a precision comparator with TTL compatible output.

**Comparator Rise Response Time to 10mV, 5mV, 2mV Overdrives**

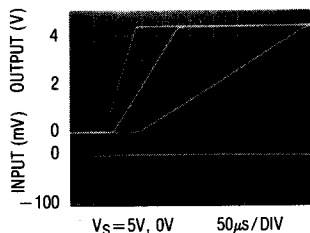

**Comparator Fall Response Time to 10mV, 5mV, 2mV Overdrives**

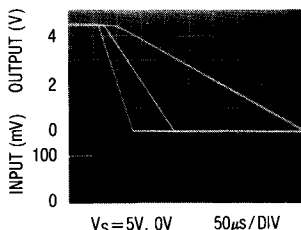

LT1006 SCHEMATIC DIAGRAM

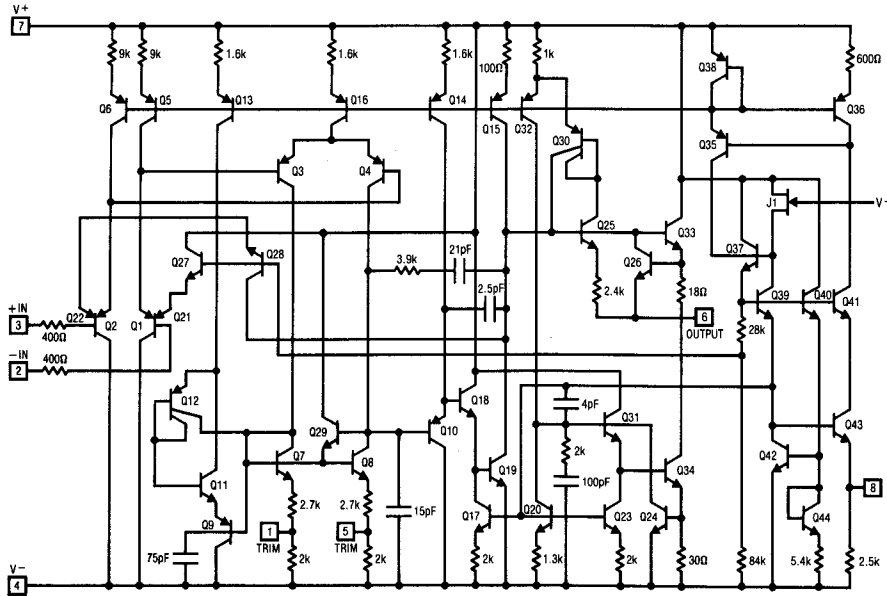

PACKAGE DESCRIPTION Dimensions in inches (millimeters) unless otherwise noted.

H8 Package  
TO-5 Metal Can

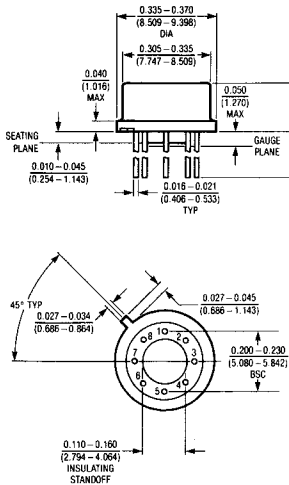

$T_{max}$	$\theta_{JA}$	$\theta_{JC}$
150°C	150°C/W	45°C/W

J8 Package  
Hermetic DIP

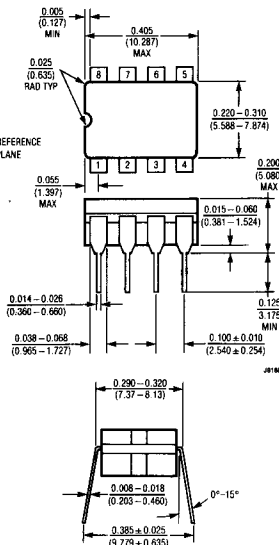

$T_{max}$	$\theta_{JA}$
150°C	100°C/W

N8 Package  
Plastic DIP

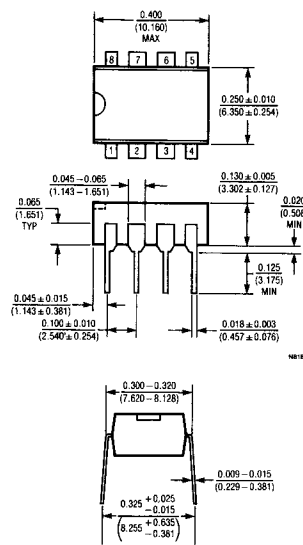

$T_{max}$	$\theta_{JA}$
100°C	130°C/W