

S-AV12

VHF HAM FM RF POWER AMPLIFIER MODULE
Hand-Held Transceiver Application.

Unit in mm

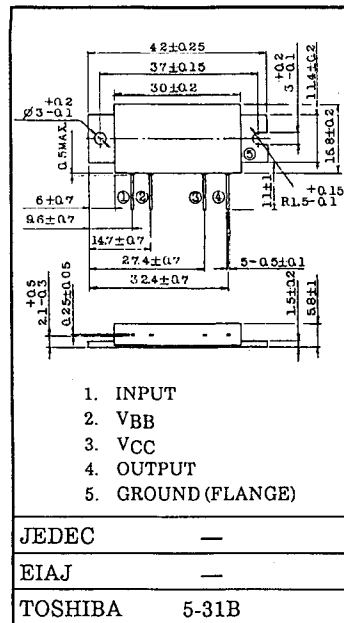

MAXIMUM RATINGS (T_c = 25°C)

CHARACTERISTIC	SYMBOL	RATING	UNIT
DC Supply Voltage	V _{CC}	16	V
DC Supply Voltage	V _{BB}	6	V
Input Power	P _i	300	mW
Operating Case Temperature Range	T _{c(op)}	-30~100	°C
Storage Temperature Range	T _{stg}	-40~110	°C

ELECTRICAL CHARACTERISTICS (T_c = 25°C)

Weight : 8.8g

CHARACTERISTIC	SYMBOL	TEST CONDITION	MIN.	TYP.	MAX.	UNIT
Frequency Range	f _{range}	—	144	—	148	MHz
Output Power	P _o *	P _i =150mW V _{CC} =10.8V, V _{BB} =5V Z _G =Z _L =50Ω	5	—	—	W
Total Efficiency	η _T		45	—	—	%
Input VSWR	VSMR _{in}		—	—	2	—
Harmonics	HRM		—	—	-20	dB
Load Mismatch	—	V _{CC} =13.2V P _i =150mW, V _{BB} =5V VSWR Load 20:1 all phase	No Degradation			—
Stability	—	V _{CC} =5~13.2V P _i =150mW, V _{BB} =5V VSWR Load 6:1 all phase	All spurious output than 60dB below desired signal			—

* P_o ≥ 3W @V_{CC}=8.4V
P_o ≥ 7W @V_{CC}=13.2V

CAUTION

- This product has intersetting cap. Please pay attention for exceeding stress and foreign matter in your application. And not to take away the cap.
- Beryllia Ceramics is used in this product. The dust or vapor can be dangerous to humans. Do not break, cut, crush or dissolve chemically. Dispose of this product properly according to law. Do not intermingle with normal industrial or domestic waste.

SCHEMATIC

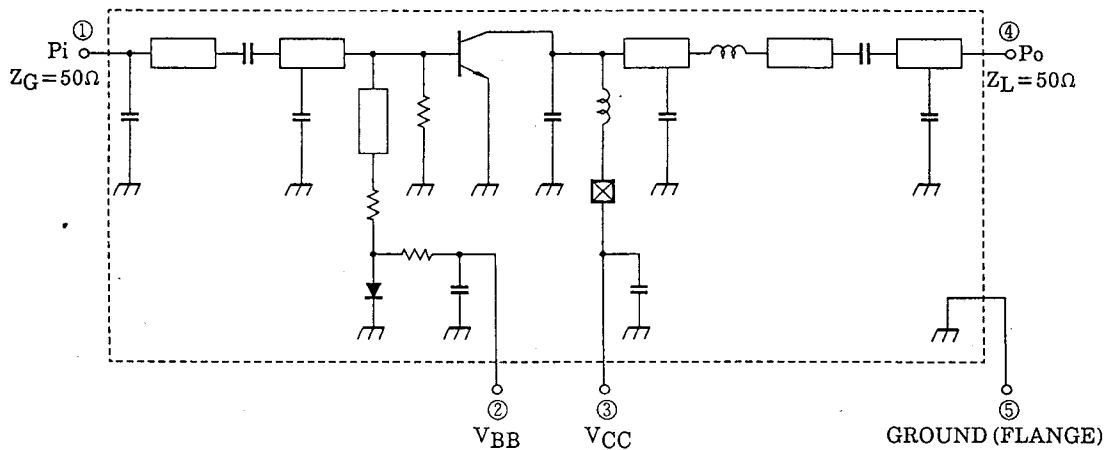

TEST FIXTURE

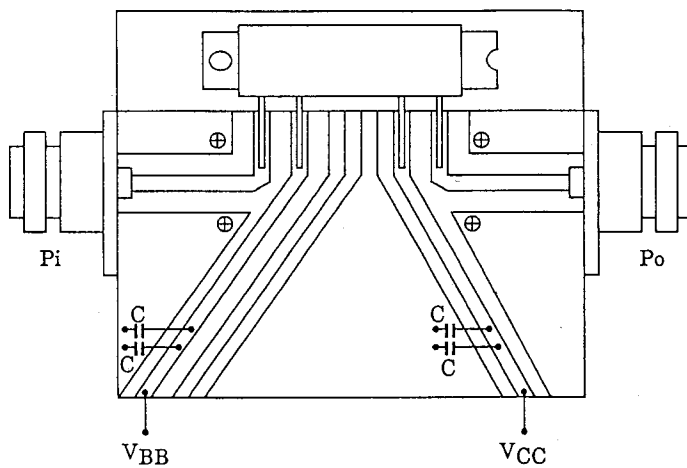

C : 22000pF, 10 μ F PARALLEL

Po, η_T , VSWRin - Pi

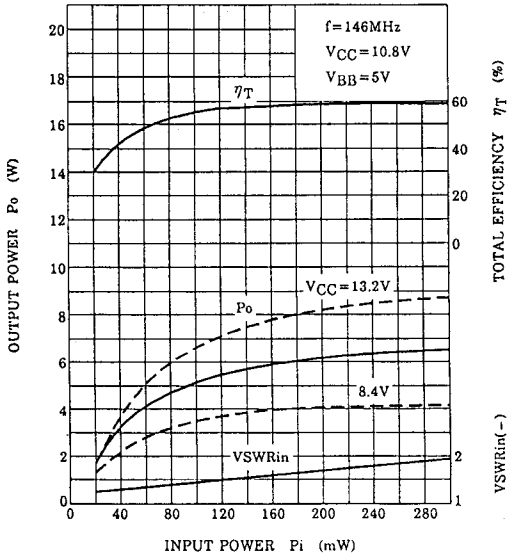

Po, η_T , VSWRin - f

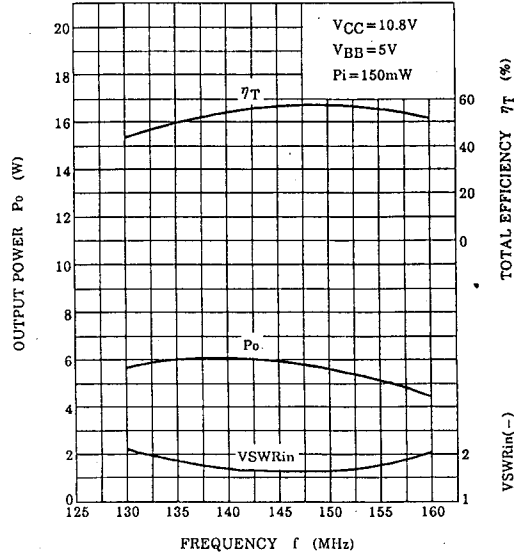

Po, η_T , VSWRin - VCC

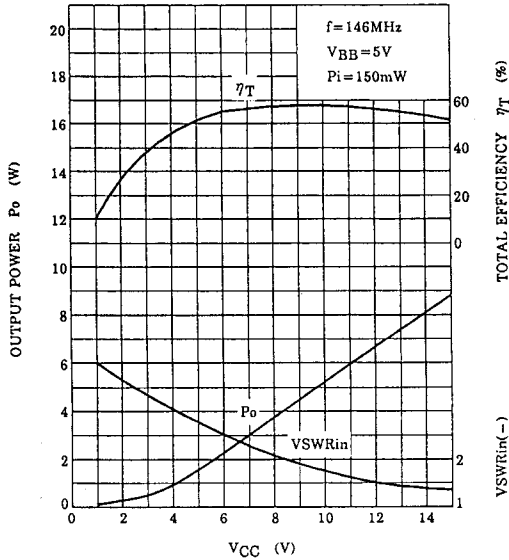

S-AV22A

VHF BAND HAM FM RF POWER AMPLIFIER MODULE
HAND-HELD TRANSCEIVER

- High Gain ($P_o \geq 7W$, $G_p = 26.6dB$ Min.)
- Small Package

MAXIMUM RATINGS ($T_c = 25^\circ C$)

CHARACTERISTIC	SYMBOL	RATING	UNIT
DC Supply Voltage	V_{CC}	16	V
DC Supply Voltage	V_{CON}	16	V
DC Supply Voltage	V_{BB}	5.5	V
Input Power	P_i	30	mW
Output Power	P_o	10	W
Total current	I_T	2	A
Operating Case Temperature Range	T_c (opr)	-30~100	$^\circ C$
Storage Temperature Range	T_{stg}	-40~110	$^\circ C$

Unit in mm

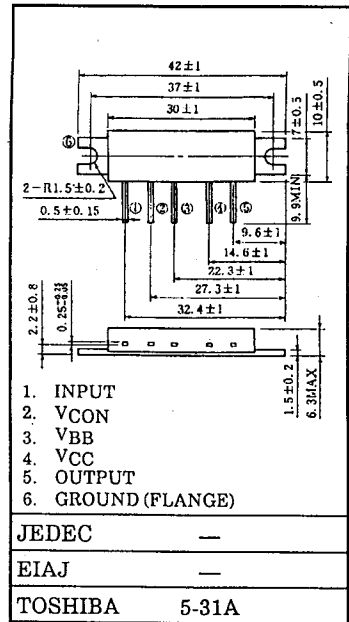

ELECTRICAL CHARACTERISTICS ($T_c = 25^\circ C$)

Weight : 5.4g

CHARACTERISTIC	SYMBOL	TEST CONDITION	MIN.	TYP.	MAX.	UNIT
Frequency Range	f_{range}	—	144	—	148	MHz
Output Power	P_o	$V_{CC} = V_{CON} = 12.5V$ $V_{BB} = 5V$ $P_i = 15mW$ $Z_G = Z_L = 50\Omega$	7	—	—	W
Power Gain	G_p		26.6	—	—	dB
Total Efficiency	η_T		45	—	—	%
Input VSWR	VSWR _{in}		—	—	2.5	—
Harmonics	HRM		—	—	-15	dB
Load Mismatch	—	$P_o = 7.5W$, $P_i = \text{Adjust}$ $V_{CC} = V_{CON} = 15V$, $V_{BB} = 5V$ VSWR load 20:1 all phase	No Degradation			—
Stability	—	$V_{CC} = V_{CON} = 5\sim 13V$ $V_{BB} = 5V$, $P_o < 10W$ $P_i = 0\sim 20mW$ VSWR load 6:1 all phase	All spurious output than 60dB below desired signal			—

Caution

- This product has intersetting cap. Please pay attention for exceeding stress and foreign matter in your application. And not to take away the cap.
- Beryllia Ceramics is used in this product. The dust or vapor can be dangerous to humans. Do not break, cut, crush or dissolve chemically. Dispose of this product properly according to law. Do not intermingle with normal industrial or domestic waste.

S-AV22A

SCHEMATIC

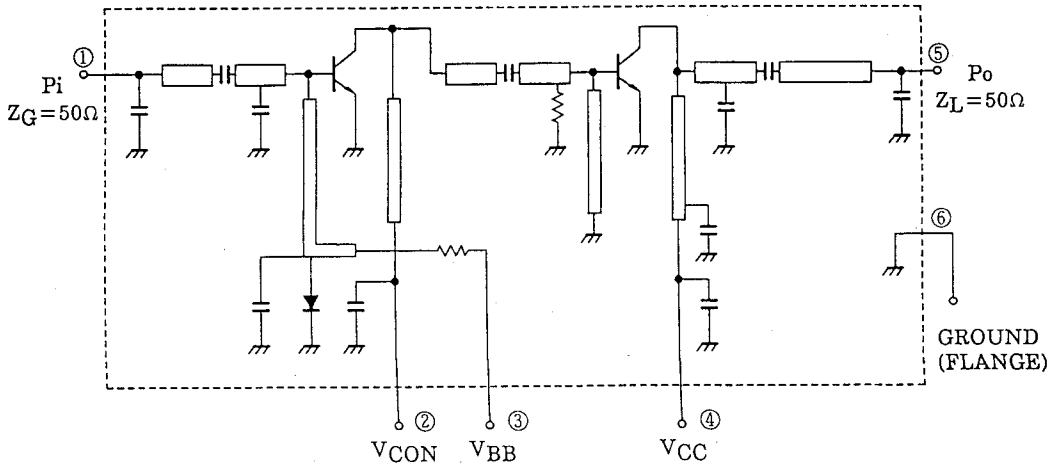

TEST FIXTURE

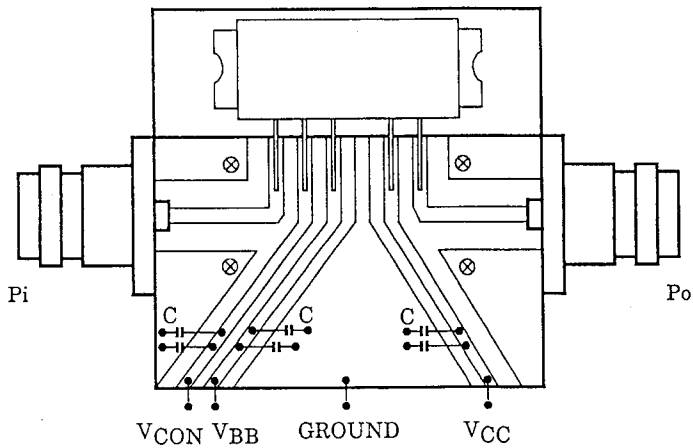

C : $0.1\mu F, 10\mu F$ PARALLEL

Po, η_T , VSWRin - Pi

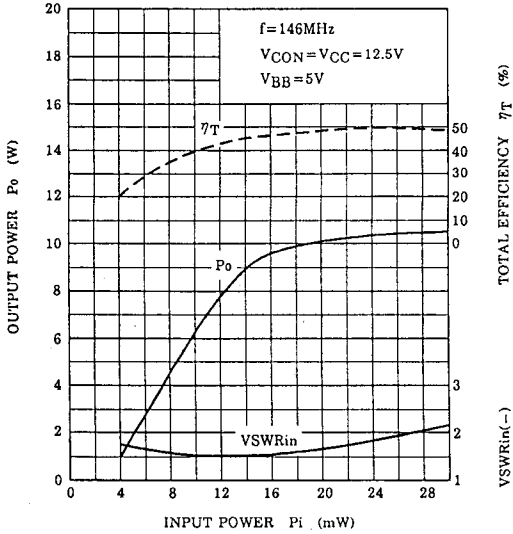

Po, η_T , VSWRin - f

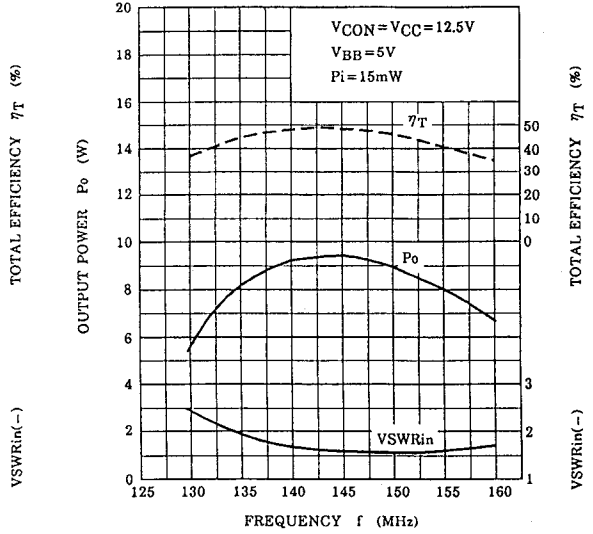

Po, η_T , VSWRin - VCON, VCC

