



# INTEGRATED CIRCUIT

## TECHNICAL DATA

# TA7140P

TOSHIBA BIPOLAR LINEAR INTEGRATED CIRCUIT  
SILICON MONOLITHIC

### VOLTAGE AMPLIFIER

### LOW OUTPUT POWER AMPLIFIER

- Especially Suitable for Line Output Amplifier  
Recording Head Driver and Headphone Driver of Tape Recorder Deck.
- Low Noise :  $V_{NI}=1\mu V_{rms}$
- Wide Operating Supply Voltage Range  
:  $V_{CC}=3.5\sim 25V$
- 150mW Audio Output Power at  $V_{CC}=20V, R_L=150\Omega$

Unit in mm

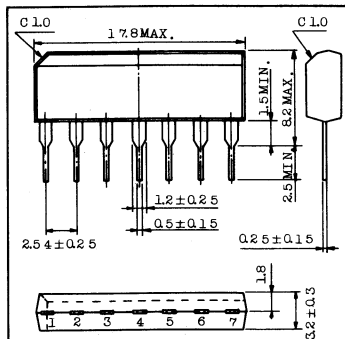

Lead pitch is 2.54 and tolerance is  $\pm 0.25$  against theoretical center of each lead that is obtained on the basis of No.1 lead.

JEDEC	-
TOSHIBA	5-18A

### MAXIMUM RATINGS (Ta=25°C)

CHARACTERISTIC	SYMBOL	RATING	UNIT
Supply Voltage	$V_{CC}$	25	V
Power Dissipation (Note)	$P_D$	400	mW
Operating Temperature	$T_{opr}$	-25 ~ 75	°C
Storage Temperature	$T_{stg}$	-55 ~ 125	°C

Note: Derated above Ta=25°C in the proportion of 4mW/°C.

### ELECTRICAL CHARACTERISTICS (Unless otherwise specified)

$V_{CC}=20V, T_a=25^\circ C, R_L=150\Omega, R_f=100\Omega, R_g=600\Omega, f=1kHz$

CHARACTERISTIC	SYMBOL	TEST CIRCUIT	TEST CONDITION	MIN.	TYP.	MAX.	UNIT
Operating Supply Voltage Range	$V_{CCopr}$	-	-	3.5	20	25	V
Supply Current	$I_{CC}$	-	$f=1kHz$ $V_{OUT}=0$	-	4.0	6.0	mA
			$V_{OUT}=4.5V_{rms}$	-	16.5	-	
Voltage Gain (Open Loop)	$G_{VO}$	-	$R_f=0\Omega$	-	63	-	dB
Voltage Gain (Closed Loop) (Note)	$G_V$	-	-	36.5	40	43.5	dB
Total Harmonic Distortion	THD	-	$V_{OUT}=4.5V_{rms}$	-	0.5	1	%
			$V_{CC}=6.5V, V_{OUT}=1.0V_{rms}$	-	1	-	%
Maximum Output Voltage	$V_{OM}$	-	THD=10%	-	6	-	$V_{rms}$
Input Resistance	$R_{IN}$	-	-	-	30	-	k $\Omega$
Output Noise Voltage	$V_{NO}$	-	BW=20Hz ~ 20kHz, $R_g=1k\Omega$	-	100	200	$\mu V_{rms}$

Note: In regard to the value of voltage gain (closed loop), it is possible to be classified.

TA7140P



# INTEGRATED CIRCUIT

## TA7140P

### TECHNICAL DATA

#### EQUIVALENT CIRCUIT

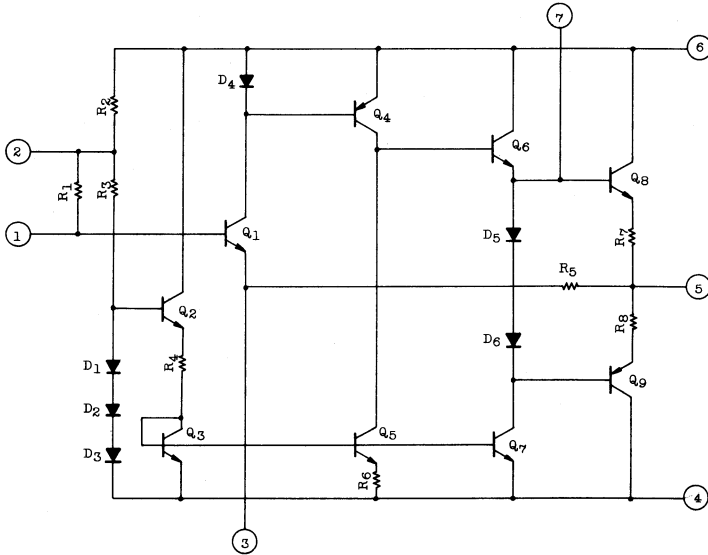

#### TEST CIRCUIT

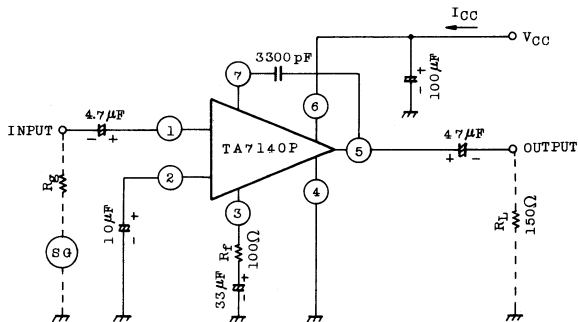



# INTEGRATED CIRCUIT

## TA7140P

### TECHNICAL DATA

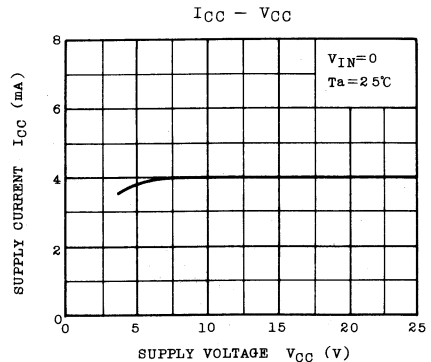
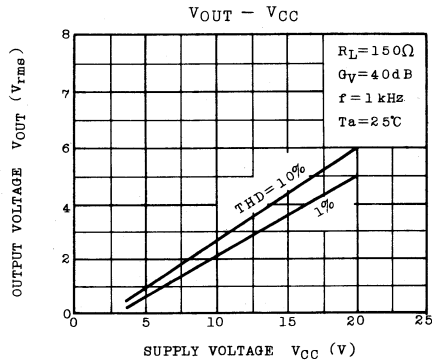
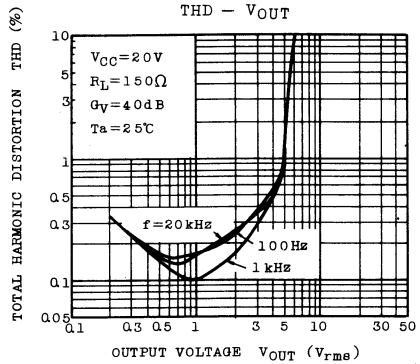
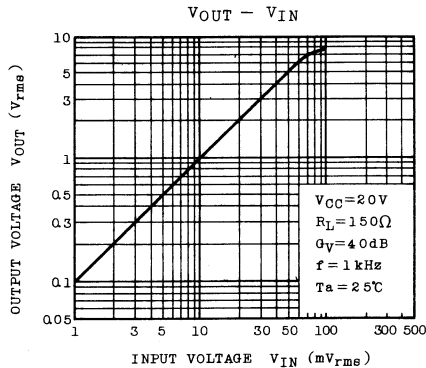
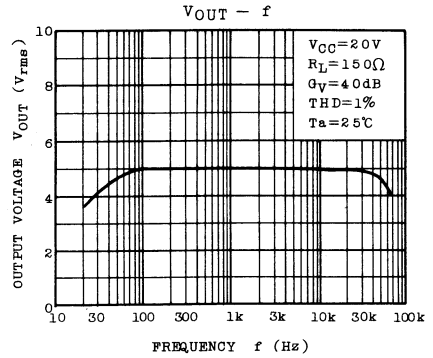
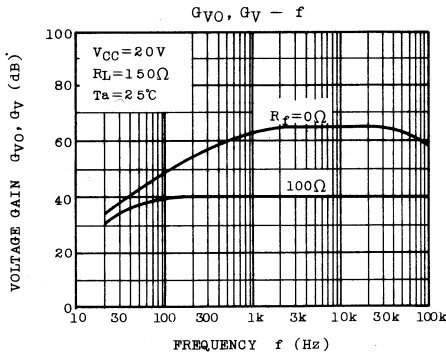



# INTEGRATED CIRCUIT

## TA7140P

### TECHNICAL DATA

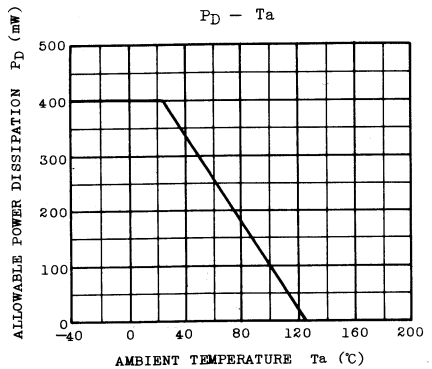
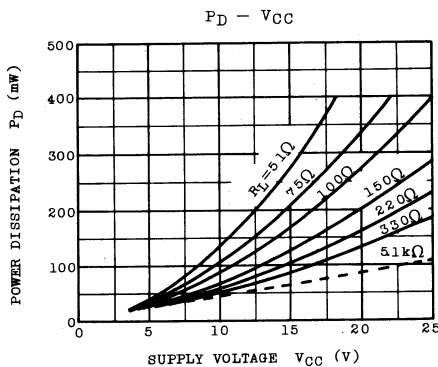
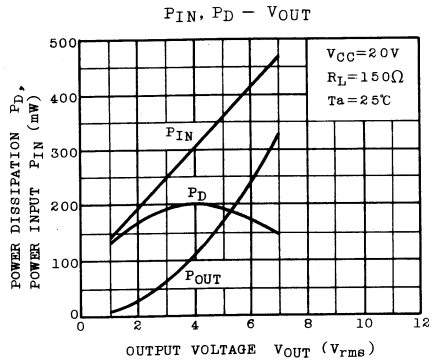
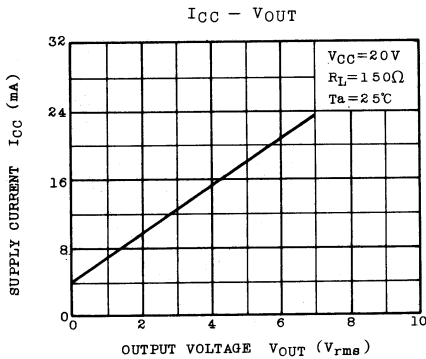
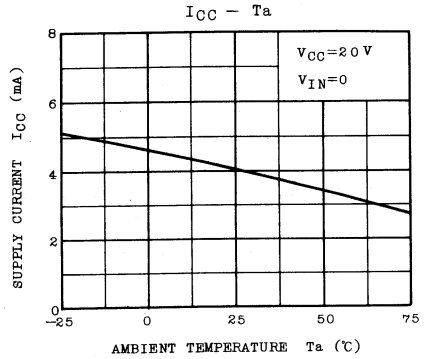
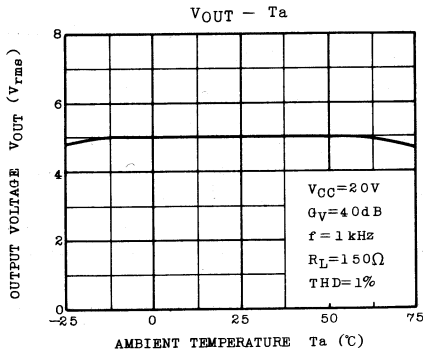



# INTEGRATED CIRCUIT

TA7140P

## TECHNICAL DATA

### APPLICATION CIRCUIT

#### 1. HEADPHONE AMPLIFIER

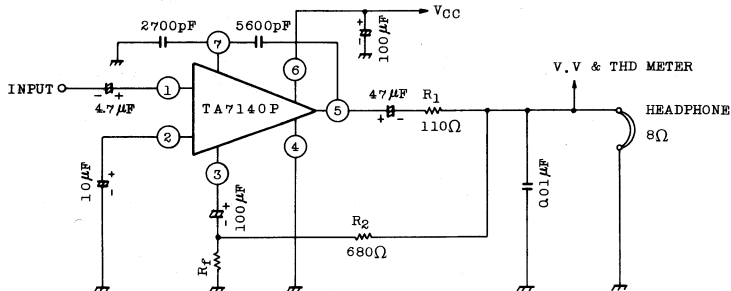

#### 2. BUFFER AMPLIFIER ( $G_v=9\text{dB}$ )

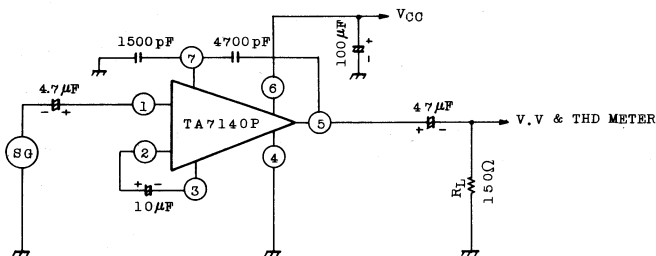

#### 3. FLAT AMPLIFIER

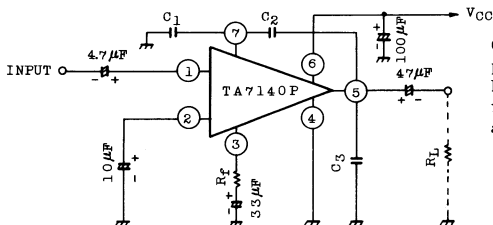

$C_1, C_2$  and  $C_3$  are for preventing parasitic oscillation. For various closed loop gain, recommended compensation values are shown in the following table.

#### VOLTAGE GAIN

$G_v$	40dB	30dB	20dB	10dB	0dB
$R_f$ [ $\Omega$ ]	100	330	1.1k	4.7k	$\infty$ (open)
$C_1$ [pF]	0	1500	1500	1500	1500
$C_2$ [pF]	3300	4700	4700	4700	4700
$C_3$ [pF]	0	0	0	0	2200



# INTEGRATED CIRCUIT

## TECHNICAL DATA

# TA7140P

