

**6A HIGH-SPEED MOSFET DRIVERS**

**FEATURES**

- Tough CMOS™ Construction
- Latch-Up Protected: Will Withstand >1.5A Reverse Output Current
- Logic Input Will Withstand Negative Swing Up to 5V
- ESD Protected ..... 4 kV
- Matched Rise and Fall Times ..... 25 ns
- High Peak Output Current ..... 6A Peak
- Wide Operating Range ..... 4.5V to 18V
- High Capacitive Load Drive ..... 10,000 pF
- Low Delay Time ..... 55 ns Typ
- Logic High Input, Any Voltage ..... 2.4V to V<sub>DD</sub>
- Low Supply Current With Logic "1" Input... 450 μA
- Low Output Impedance ..... 2.5Ω
- Output Voltage Swing to Within 25 mV of Ground or V<sub>DD</sub>

**APPLICATIONS**

- Switch-Mode Power Supplies
- Motor Controls
- Pulse Transformer Driver
- Class D Switching Amplifiers

**6**

**FUNCTIONAL DIAGRAM**

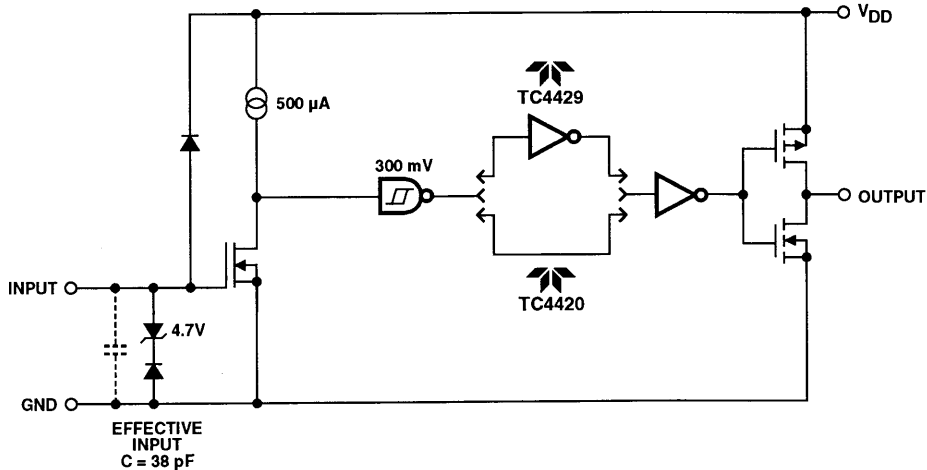

## 6A HIGH-SPEED MOSFET DRIVERS

### TC4420 TC4429

#### GENERAL DESCRIPTION

The TC4420/4429 Tough CMOS™ drivers are efficient and easy to use. These devices are 6A (peak) single output MOSFET drivers.

The TC4420/4429 will drive even the largest MOSFETs.

These devices are tough due to extra steps taken to protect them from failures. An epitaxial layer is used to prevent CMOS latch-up. Proprietary circuits allow the input to swing negative as much as 5V without damaging the part. Special circuits have been added to protect against damage from electrostatic discharge. A special molding compound is used for increased moisture resistance and ability to withstand high voltages. They are also tough

because of Teledyne Components' world-class process controls and device quality.

Because these devices are fabricated in CMOS, they run cool, use less power and are easier to drive. The rail-to-rail swing capability of CMOS better insures adequate gate voltage to the MOSFET during power up/down sequencing.

The Tough CMOS™ drivers are easy to use. Three or more discrete components can be replaced with a single device to save PCB area. Any logic input from 2.4V to  $V_{DD}$  can be used without external speed-up capacitors or resistor networks.

This family is available in inverting (TC4429) and noninverting (TC4420) configurations. The TC4429 is pin compatible with the popular TC429.

#### ORDERING INFORMATION

Part No.	Logic	Package	Temperature Range
TC4420CPA	Noninverting	8-Pin PDIP	0°C to +70°C
TC4420EPA	Noninverting	8-Pin PDIP	-40°C to +85°C
TC4420COA	Noninverting	8-Pin SOIC	0°C to +70°C
TC4420EOA	Noninverting	8-Pin SOIC	-40°C to +85°C
TC4420IJA	Noninverting	8-Pin CerDIP	-25°C to +85°C
TC4420MJA	Noninverting	8-Pin CerDIP	-55°C to +125°C
TC4420CAT	Noninverting	5-Pin TO-220	0°C to +70°C
TC4429CPA	Inverting	8-Pin PDIP	0°C to +70°C
TC4429EPA	Inverting	8-Pin PDIP	-40°C to +85°C
TC4429COA	Inverting	8-Pin SOIC	0°C to +70°C
TC4429EOA	Inverting	8-Pin SOIC	-40°C to +85°C
TC4429IJA	Inverting	8-Pin CerDIP	-25°C to +85°C
TC4429MJA	Inverting	8-Pin CerDIP	-55°C to +125°C
TC4429CAT	Inverting	5-Pin TO-220	0°C to +70°C

#### PIN CONFIGURATIONS

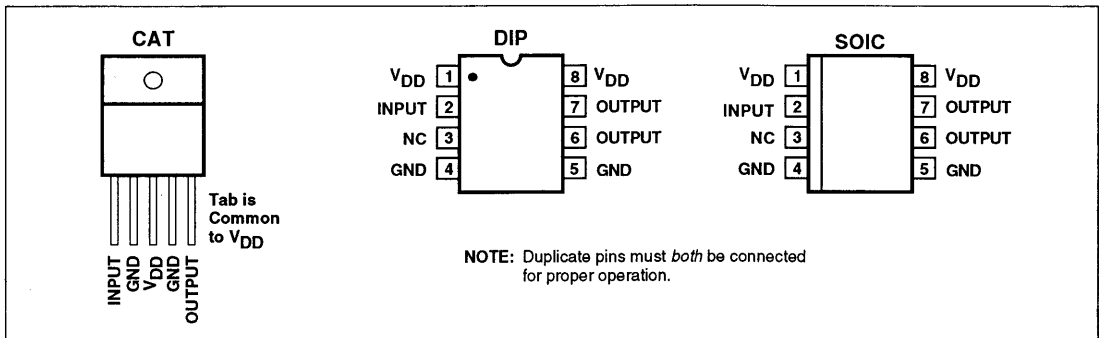

## ABSOLUTE MAXIMUM RATINGS

Supply Voltage .....	+20V
Input Voltage .....	-5V to $>V_{DD}$
Input Current ( $V_{IN} > V_{DD}$ ) .....	50 mA
Power Dissipation, $T_A \leq 25^\circ\text{C}$	
PDIP .....	1W
SOIC .....	500 mW
CerDIP .....	800 mW
5-Pin TO-220 .....	1.5W
Power Dissipation, $T_C \leq 25^\circ\text{C}$	
5-Pin TO-220 .....	12.5W
Derating Factors (To Ambient)	
PDIP .....	8 mW/ $^\circ\text{C}$
SOIC .....	4 mW/ $^\circ\text{C}$
CerDIP .....	6.4 mW/ $^\circ\text{C}$
5-Pin TO-220 .....	12 mW/ $^\circ\text{C}$
Thermal Impedances (To Case)	
5-Pin TO-220 $R_{\theta J-A}$ .....	10 $^\circ\text{C}/\text{W}$

Storage Temperature Range .....	-55 $^\circ\text{C}$ to +150 $^\circ\text{C}$
Operating Temperature (Chip) .....	+150 $^\circ\text{C}$
Operating Temperature Range (Ambient)	
C Version .....	0 $^\circ\text{C}$ to +70 $^\circ\text{C}$
I Version .....	-25 $^\circ\text{C}$ to +85 $^\circ\text{C}$
E Version .....	-40 $^\circ\text{C}$ to +85 $^\circ\text{C}$
M Version .....	-55 $^\circ\text{C}$ to +125 $^\circ\text{C}$
Lead Temperature (Soldering, 10 sec) .....	+300 $^\circ\text{C}$

Static-sensitive device. Unused devices must be stored in conductive material. Protect devices from static discharge and static fields. Stresses above those listed under "Absolute Maximum Ratings" may cause permanent damage to the device. These are stress ratings only and functional operation of the device at these or any other conditions above those indicated in the operation sections of the specifications is not implied. Exposure to absolute maximum rating conditions for extended periods may affect device reliability.

6

ELECTRICAL CHARACTERISTICS:  $T_A = +25^\circ\text{C}$  with  $4.5\text{V} \leq V_{DD} \leq 18\text{V}$ , unless otherwise specified.

Symbol	Parameter	Test Conditions	Min	Typ	Max	Unit
<b>Input</b>						
$V_{IH}$	Logic 1 High Input Voltage		2.4	1.8	—	V
$V_{IL}$	Logic 0 Low Input Voltage		—	1.3	0.8	V
$V_{IN}(\text{Max})$	Input Voltage Range		-5	—	$V_{DD}+0.3$	V
$I_{IN}$	Input Current	$0\text{V} \leq V_{IN} \leq V_{DD}$	-10	—	10	$\mu\text{A}$
<b>Output</b>						
$V_{OH}$	High Output Voltage	See Figure 1	$V_{DD}-0.025$	—	—	V
$V_{OL}$	Low Output Voltage	See Figure 1	—	—	0.025	V
$R_O$	Output Resistance, High	$I_{OUT} = 10\text{ mA}$ , $V_{DD} = 18\text{V}$	—	2.1	2.8	$\Omega$
$R_O$	Output Resistance, Low	$I_{OUT} = 10\text{ mA}$ , $V_{DD} = 18\text{V}$	—	1.5	2.5	$\Omega$
$I_{PK}$	Peak Output Current	$V_{DD} = 18\text{V}$ (See Figure 5)	—	6	—	A
$I_{REV}$	Latch-Up Protection Withstand Reverse Current	Duty Cycle $\leq 2\%$ $t \leq 300\ \mu\text{s}$	>1.5	—	—	A
<b>Switching Time (Note 1)</b>						
$t_R$	Rise Time	Figure 1, $C_L = 2500\text{ pF}$	—	25	35	ns
$t_F$	Fall Time	Figure 1, $C_L = 2500\text{ pF}$	—	25	35	ns
$t_{D1}$	Delay Time	Figure 1	—	55	75	ns
$t_{D2}$	Delay Time	Figure 1	—	55	75	ns
<b>Power Supply</b>						
$I_S$	Power Supply Current	$V_{IN} = 3\text{V}$ $V_{IN} = 0\text{V}$	—	0.45 55	1.5 150	mA $\mu\text{A}$
$V_{DD}$	Operating Input Voltage		4.5	—	18	V

# 6A HIGH-SPEED MOSFET DRIVERS

## TC4420 TC4429

### ELECTRICAL CHARACTERISTICS:

Measured over operating temperature range with  $4.5V \leq V_{DD} \leq 18V$ , unless otherwise specified.

Symbol	Parameter	Test Conditions	Min	Typ	Max	Unit
<b>Input</b>						
$V_{IH}$	Logic 1 High Input Voltage		2.4	—	—	V
$V_{IL}$	Logic 0 Low Input Voltage		—	—	0.8	V
$V_{IN (Max)}$	Input Voltage Range		-5	—	$V_{DD}+0.3$	V
$I_{IN}$	Input Current	$0V \leq V_{IN} \leq V_S$	-10	—	10	$\mu A$
<b>Output</b>						
$V_{OH}$	High Output Voltage	See Figure 1	$V_{DD}-0.025$	—	—	V
$V_{OL}$	Low Output Voltage	See Figure 1	—	—	0.025	V
$R_O$	Output Resistance, High	$I_{OUT} = 10 \text{ mA}$ , $V_{DD} = 18V$	—	3	5	$\Omega$
$R_O$	Output Resistance, Low	$I_{OUT} = 10 \text{ mA}$ , $V_{DD} = 18V$	—	2.3	5	$\Omega$
<b>Switching Time (Note 1)</b>						
$t_R$	Rise Time	Figure 1, $C_L = 2500 \text{ pF}$	—	32	60	ns
$t_F$	Fall Time	Figure 1, $C_L = 2500 \text{ pF}$	—	34	60	ns
$t_{D1}$	Delay Time	Figure 1	—	50	100	ns
$t_{D2}$	Delay Time	Figure 1	—	65	100	ns
<b>Power Supply</b>						
$I_S$	Power Supply Current	$V_{IN} = 3V$ $V_{IN} = 0V$	—	0.45 60	3 400	mA $\mu A$
$V_{DD}$	Operating Input Voltage		4.5	—	18	V

NOTE: 1. Switching times guaranteed by design.

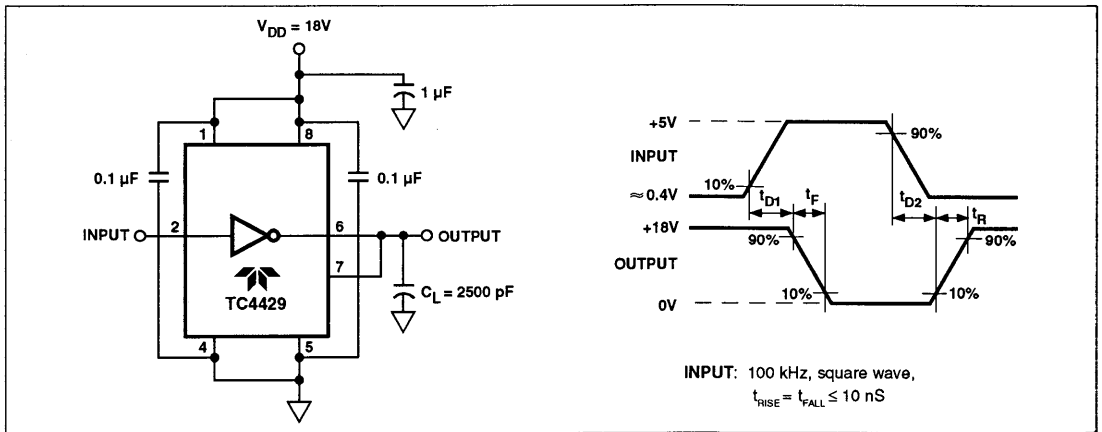
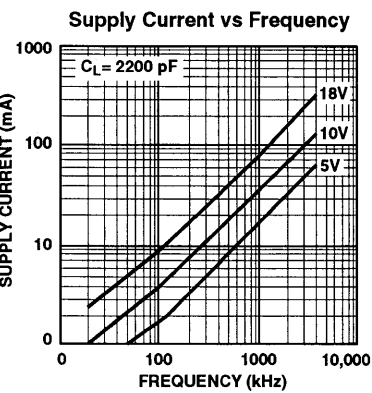
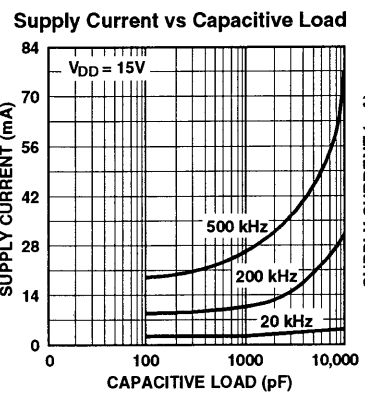
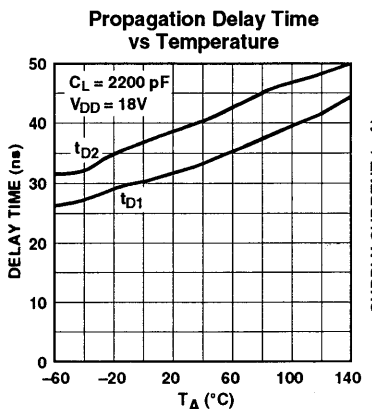
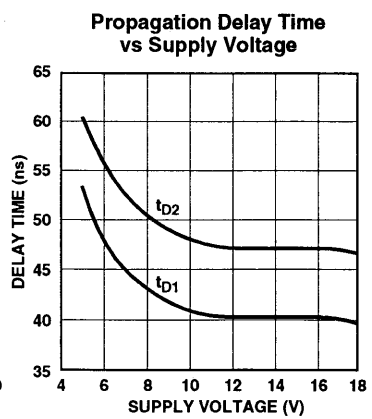
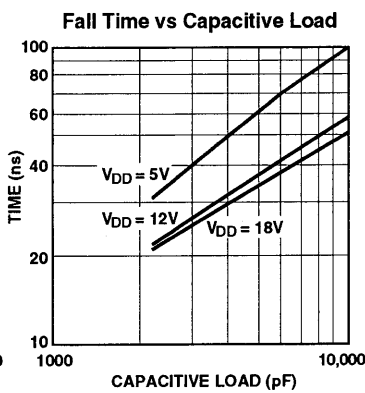
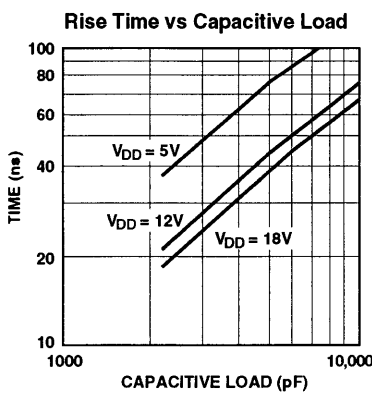
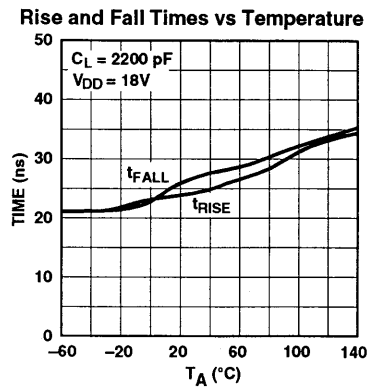
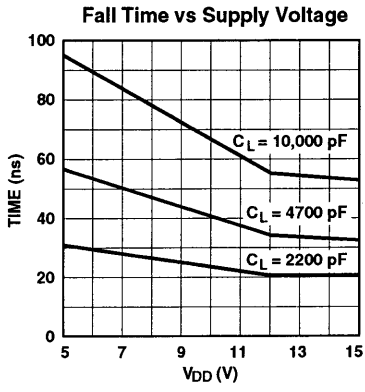
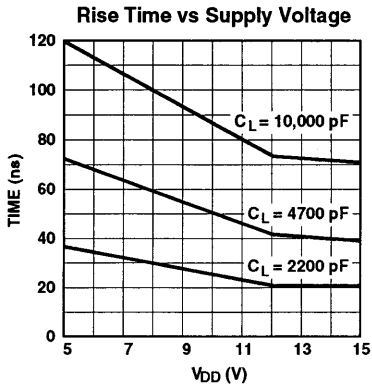

Figure 1. Switching Time Test Circuit

TYPICAL CHARACTERISTICS CURVES



TC4420  
TC4429

## TYPICAL CHARACTERISTICS CURVES (Cont.)

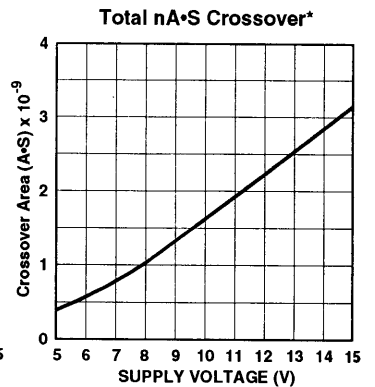
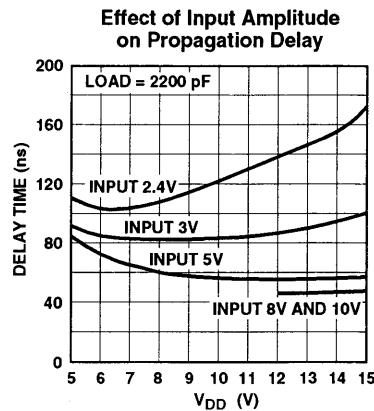
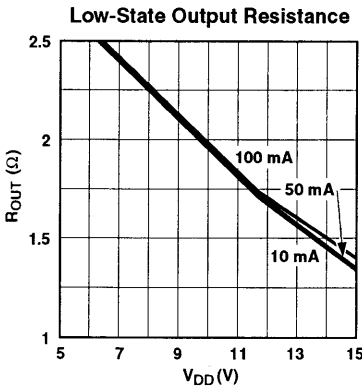
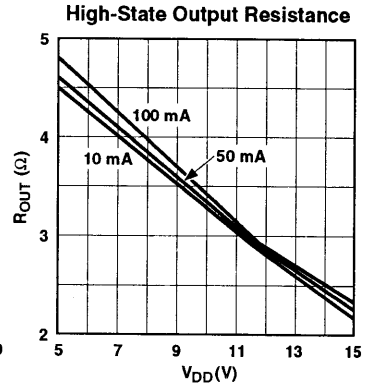
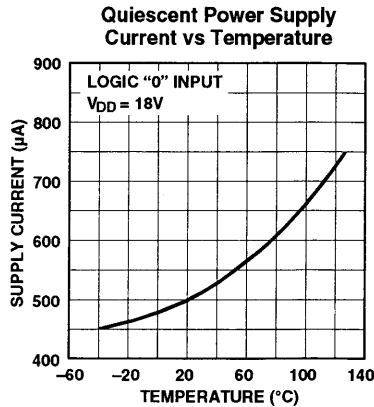
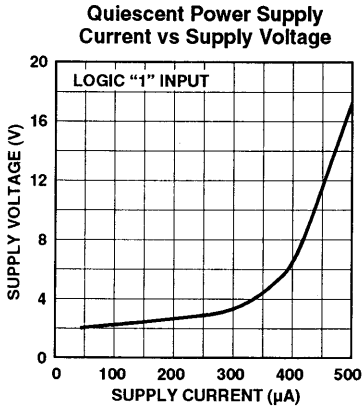

## BONDING DIAGRAM

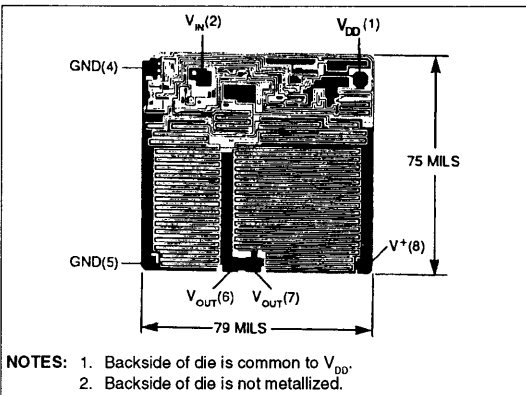

\* The values on this graph represent the loss seen by the driver during one complete cycle. For a single transition, divide the value by 2.